



Electric Product Line

July 2017

Admiral Craft Equipment Corporation
800 Shames Drive
Westbury, NY 11590
P: 1-800-223-7750
F: 1-800-447-7751
info@admiralcraft.com
www.admiralcraft.com



The more you look, the better we look.

Bun Warmer

BW-450

- Interior and exterior constructed of heavy stainless steel
- Includes removable stainless steel pan and bun rack
- 32 standard size bun capacity
- Provides gentle warming heat for buns
- Measures 9-3/4"H x 23-1/2"W x 21-1/2"D
- 120V, 450W, 3.75 amps



ADCRAFT®

NEMA 5-15 PLUG
120V/15 Amps



Protected by Admiral Craft Equipment Corporation's one year limited warranty. Should your product fail under normal use, it will be repaired or replaced up to one year from date of purchase.



The more you look, the better we look.

Stainless Steel Coffee Brewer

Cafetera de Acero Inoxidable

CBS-2

- All parts manufactured of heavy duty stainless steel
Todas las partes manufacturadas de acero inoxidable de alta calidad
- Only 8 minutes to brew a full pot of coffee
Solo 8 minutos para preparar una jarra llena de café
- Two independent switches for warming and brewing
Dos interruptores independientes para calefacción y preparación
- Brewing indicator alerts you when brewing cycle is complete
Luz indicadora alerta cuando el ciclo de preparación es completo
- Heating plates ensure optimal temperature is maintained for extended periods
Placas calentadoras que garantizan una óptima temperatura son mantenidas por largos periodos
- Accepts standard filters and decanters
Acepta filtros y jarras standard
- Narrow space saving design
Diseño angosto que ahorra espacio
- 120V, 50-60Hz, 1650W, 13.75 Amps
- ETL Listed, ETL Sanitation



ADCRAFT®

NEMA 5-15 PLUG
120V/15 Amps



Protected by Admiral Craft Equipment Corporation's one year limited warranty. Should your product fail under normal use, it will be repaired or replaced up to one year from date of purchase.



The more you look, the better we look.

Pizza/Snack Oven

Horno de Pizza/Antojito

CK-2

- Stainless Steel exterior construction
Construcción de acero inoxidable
- 13-1/2" rack accomodates 12" diameter products 2-1/2" high
La bandeja de 13-1/2" pulgadas accomoda productos de 12" por 2-1/2" pulgadas
- Upper and lower heating elements
Elementos de hornear en la parte superior y debajo
- 450° pre-set thermostat
Solo cambie el termostato a 450°
- On/off operation controlled by a 30 minute timer
El uso de el horno esta controlado por un temporizador de 30 minutos
- Convenient crumb tray for easy cleanup
La bandeja para migajas ficilita la limpieza
- 120V, 1450W, 12 Amps
- UL



ADCRAFT®

NEMA 5-15 PLUG
120V/15 Amps



Protected by Admiral Craft Equipment Corporation's one year limited warranty. Should your product fail under normal use, it will be repaired or replaced up to one year from date of purchase.



The more you look, the better we look.

Half Size Convection Oven

COH-2670W

- All parts constructed of heavy duty stainless steel
- Small footprint design perfect for countertops
- 120° to 570°F temperature range
- Double wall glass door
- Manual control knobs
- 120 minute timer
- Handles four half size sheet pans
- 3" spacing between shelves
- Unit exterior dimensions: 21.75"H x 23.5"W x 21"D
- 220V, 60hz, 2670W, 12 Amps
- NSF



ADCRAFT®

NEMA 6-20 PLUG
208V, 240V/15 Amps



Protected by Admiral Craft Equipment Corporation's one year limited warranty. Should your product fail under normal use, it will be repaired or replaced up to one year from date of purchase.



The more you look, the better we look.

Professional Half Size Convection Oven

COH-3100WPRO

- All parts constructed of heavy duty stainless steel
- Small footprint design perfect for countertops
- 120° to 500°F temperature range
- Features a grill/broil function (570°F)
- Cook and hold feature keeps food warm up to 180 minutes
- Handles four half size sheet pans
- 3.5" spacing between shelves
- Double wall glass door
- Manual control knobs
- 60 minute timer
- Interior light
- Unit exterior dimensions: 22"H x 31"W x 21.5"D
- 220V, 60hz, 3100W, 14 Amps
- NSF



ADCRAFT®

NEMA 6-20 PLUG
208V, 240V/15 Amps



Protected by Admiral Craft Equipment Corporation's one year limited warranty. Should your product fail under normal use, it will be repaired or replaced up to one year from date of purchase.



The more you look, the better we look.

Quarter Size Convection Oven COQ-1750W

- All parts constructed of heavy duty stainless steel
- Compact design perfect for countertops
- 120° to 480°F temperature range
- Handles three quarter size sheet pans
- 3.5" spacing between shelves
- Double wall glass door
- Manual control knobs
- 120 minute timer
- Unit exterior dimensions: 12.5"H x 20.75"W x 15.5"D
- 120V, 60hz, 1750W, 14.5 Amps
- NSF



ADCRAFT®

NEMA 5-15 PLUG
120V/15 Amps



Protected by Admiral Craft Equipment Corporation's one year limited warranty. Should your product fail under normal use, it will be repaired or replaced up to one year from date of purchase.



The more you look, the better we look.

Stainless Steel Coffee Percolators

Percoladora en Acero Inoxidable

CP-40
CP-60
CP-100

- Temperature control keeps coffee hot and ready to serve
Control de temperatura mantiene el café y listo para servir
- Red indicator light signals when coffee is done brewing
Luz indicadora roja indica cuando el café está preparando
- Available in 40, 60 and 100 cup capacities
Disponibles en capacidades de Copa de 40, 60 y 100
- Clear polycarbonate water level gauge
Indicador de nivel de agua en policarbonato
- Cool to touch handles
Agarraderas permanecen frias
- Complete with stem, coffee filter basket and cover
Viene completo con el vástago, portafiltros y tapa
- Grounded plug included
Enchufe con conexión a tierra incluido
- Mirror finish exterior
Acabado de espejo
- 120V, 1350W, 11.25 Amps
- ETL Listed, ETL Sanitation



NEMA 5-15 PLUG
120V/15 Amps



Protected by Admiral Craft Equipment Corporation's one year limited warranty. Should your product fail under normal use, it will be repaired or replaced up to one year from date of purchase.



ADCRAFT®



The more you look, the better we look.

Conveyor Toaster

CVYT-120

Tostadora de Banda Transportadora

- Constructed of heavy duty stainless steel
Hecho en acero inoxidable de alta resistencia
- 10" wide stainless steel conveyor belt
Banda transportadora de acero inoxidable de 10"
- Adjustable speed conveyor
Banda con velocidad ajustable
- 280-300 Slices per hour
280-300 rebanadas por hora
- Pull out crumb tray for easy cleaning
Bandeja de migajas removible para facilitar la limpieza
- Single or dual side toasting option
De un solo lado o doble opción de tostato
- Overall dimensions: 13-1/2"H x 14-1/2"W x 19-1/2"D

- 120V/1700W

- NSF



ADCRAFT®

NEMA 5-15 PLUG
120V/15 Amps



Protected by Admiral Craft Equipment Corporation's one year limited warranty. Should your product fail under normal use, it will be repaired or replaced up to one year from date of purchase.



The more you look, the better we look.

208V Deep Fryers w/Faucet

Freidoras con Grifo

DF-12L
DF-12L/2



- Heavy duty stainless steel construction
Uso industrial y construcción de acero inoxidable
- Heavy duty faucet for easier draining
Grifo resistente para facilitar drenaje
- Thermostat control switch ranges from 120° to 375°F
Interruptor para control de temperatura va de 120°-375°F
- Each tank has its own 6' grounded cord
Cada unidad tiene su propio cable con conexión a tierra de 6 pies
- Each tank holds up to 6 liters of oil and has a cooking capacity of 25 lbs/hour
Cada tanque tiene capacidad para 6 litros de aceite y tiene una capacidad de cocinar de 25 libras / hora
- Includes fryer basket(s)
Canastillas incluida
- 208V/240V, 2700-3600W(per tank) , 15 Amps
- NSF, UL



DF-12L



DF-12L/2

Item Number	Dimensions	NEMA Plug
DF-12L	11-1/2" x 18" x 16"	6-20 
DF-12L/2	22-3/4" x 18" x 16"	6-20 

Each unit requires a 15 amp circuit

Cada unidad debe ser conectada a un circuito separado de 15 amp



Protected by Admiral Craft Equipment Corporation's one year limited warranty. Should your product fail under normal use, it will be repaired or replaced up to one year from date of purchase.



ADCRAFT®



The more you look, the better we look.



120V Deep Fryers

Freidoras

DF-6L
DF-6L/2

- Heavy duty stainless steel construction
Uso industrial y construcción de acero inoxidable
- Thermostat control switch ranges from 120° to 375°F
Interruptor para control de temperatura va de 120°-375°F
- Each tank has its own 6' grounded cord
Cada unidad tiene su propio cable con conexión a tierra de 6 pies
- Each tank holds up to 6 liters of oil and has a cooking capacity of 15 lbs/hour
Cada tanque tiene capacidad para 6 litros de aceite y tiene una capacidad de cocinar de 15 libras / hora
- Includes fryer basket(s)
Canastillas incluida
- 120V, 1750W (per tank), 4.5 Amps
- NSF, UL



Item Number	Dimensions	NEMA Plug
DF-6L	11-3/4" x 16" x 11-1/4"	5-15 
DF-6L/2	21-3/4" x 16" x 11-1/4"	5-15 

Each unit requires a 15 amp circuit
Cada unidad debe ser conectada a un circuito separado de 15 amp



Protected by Admiral Craft Equipment Corporation's one year limited warranty. Should your product fail under normal use, it will be repaired or replaced up to one year from date of purchase.



ADCRAFT®





The more you look, the better we look.

Electric Griddles

Planchas Electricas

GRID-16
GRID-24
GRID-30

- Constructed of heavy duty stainless steel
Hecha en acero inoxidable de alta resistencia
- Temperature control switch ranges from 120° to 570°F
Interruptor de control de temperatura ajustable entre 120°-570°F
- 3" high side and back splashes for protection
Protección lateral y trasera de 3"
- Bottom mounted grease collection pan for easy cleaning
Bandeja de recolección de grasa en la base para facilitar la limpieza
- NSF

Item Number	Cooking Area	Voltage	Wattage	Amps	NEMA Plug
GRID-16	15.5" x 16"	120V	1750W	14.5	5-15 
GRID-24	15.5" x 24"	208V/240V	2680-3570W	14.9	6-20 
GRID-30	15.5" x 30"	208V/240V	3380-4500W	18.8	6-20 



GRID-16



GRID-24



GRID-30

ADCRAFT®



Protected by Admiral Craft Equipment Corporation's one year limited warranty. Should your product fail under normal use, it will be repaired or replaced up to one year from date of purchase.



The more you look, the better we look.

Hot Chocolate Dispensers

Dispensadores de chocolate caliente

HCD-5
HCD-10

- Stainless steel boiler tank and heating element
Tanque de acero inoxidable de la caldera y el elemento calefactor
- Bain-marie heating system
Baño María sistema de calefacción
- Continuous stir action
La acción de agitación continua
- Adjustable thermostat with digital face
Termostato regulable con cara digital
- Special "Anti-clogging" faucet
Especial contra la obstrucción del grifo
- Illuminated power switch
Interruptor de encendido con luz
- Drip tray with float indicator
Bandeja de goteo con indicador de flotador
- Overheat sensor with reset button
Sensor de sobrecalentamiento con el botón de reinicio
- 120V, 1000W, 8.3 Amps

Item Number	Capacity	Dimensions
HCD-5	5 Liters	18.25"H x 11"W x 16"D
HCD-10	10 Liters	20.25"H x 11"W x 16"D



CE

ADCRAFT

NEMA 5-15 PLUG
120V/15 Amps



Protected by Admiral Craft Equipment Corporation's one year limited warranty. Should your product fail under normal use, it will be repaired or replaced up to one year from date of purchase.



The more you look, the better we look.

Heated Displays

HD-26
HD-36
HD-48

- Double wall stainless steel construction allows outside of unit to remain cool
- Adjustable thermostat allows the internal humidifying system to keep food fresh for extended periods of time safely
- Front and rear sliding doors allow for easy filling and cleaning
- Easily adjustable shelves
- Attractive sleek design that fits on any countertop surface
- 120V, 1500W, 12.5 Amps
- ETL Sanitation



HD-26



HD-36



HD-48

Item Number	Dimensions
HD-26	25-1/4"H x 26"W x 18-3/8"D
HD-36	24"H x 35-1/2"W x 20-1/2"D
HD-48	31-3/4"H x 47-1/4"W x 20-3/8"D

NEMA 5-15 PLUG
120V/15 Amps



Protected by Admiral Craft Equipment Corporation's one year limited warranty. Should your product fail under normal use, it will be repaired or replaced up to one year from date of purchase.



ADCRAFT®



The more you look, the better we look.

Dual Heat Lamp

Lámpara Dual de Calor

HL-2

- Constructed of aluminum
Construida en aluminio
- Shades designed with a flared rim for strength and even heat distribution
Pantalla con bordes hacia afuera para mayor fuerza y distribución de calor
- On/Off switch located on arm away from heat zone
Interruptor de prendido y apagado en el mango lejos de la zona de calor
- Ceramic insulated sockets with nickel plated contacts to prevent fusing
Tomas aisladas en cerámica con contactos recubiertos en níquel que previenen fundidos
- Includes two 250 watt food safe clear bulbs
Incluye dos bombillos transparentes protector de comida de 250 vatios
- 120V, 500W, 4.1 Amps
- ETL ANSI/UL Std. 197 Approved
Certified to CAN/CSA Std. C22.2 No. 109
UL Sanitation ANSI/NSF 4 Approved



NEMA 5-15 PLUG
120V/15 Amps



Protected by Admiral Craft Equipment Corporation's one year limited warranty. Should your product fail under normal use, it will be repaired or replaced up to one year from date of purchase.



ADCRAFT®







The more you look, the better we look.

Induction Cookers

- Constructed of heavy duty stainless steel and ceramic glass
- Self checking automatic shutoff feature
- Safety overheating sensor
- Wall stopper included
- ETL Listed, ETL Sanitation, FCC

IND-A120V
 IND-B120V
 IND-C120V
 IND-C208V
 IND-E120V

Item Number Name	Power Usage	Max Cooking Temperature	Timer	NEMA Plug
IND-A120V Slim Design	120V/60hz 1800W, 15 Amps	464° F	120 minutes	5-15 
IND-B120V Full Size	120V/60hz 1800W, 15 Amps	464° F	180 minutes	5-15 
IND-C120V Manual Control	120V/60hz 1800W, 15 Amps	464° F	NA	5-15 
IND-C208V Manual Control	208V/60hz 3000W, 14.4 Amps	464° F	NA	6-20 
IND-E120V Electronic	120V/60hz 1800W, 15 Amps	460° F	170 minutes	5-15 

IND-A120V



IND-B120V



IND-C120V
IND-C208V



IND-E120V



ADCRAFT®



Protected by Admiral Craft Equipment Corporation's one year limited warranty. Should your product fail under normal use, it will be repaired or replaced up to one year from date of purchase.



The more you look, the better we look.

Drop-In Induction Cookers

IND-D120V
IND-DR120V

- Gives you the ability to convert any area into a stovetop in your kitchen or front-of-house
- Made with a cool to touch ceramic glass surface
- To be used with induction ready cookware only
- 180 minute timer
- Heats up to 464°F
- 120V, 500-1800W

Item Number Name	Dimensions
IND-D120V In-Line Digital	Overall: 14-5/8"L x 11-3/4"W x 3"H Cut Box: 13-1/2"L x 10-5/8"W
IND-DR120V Remote Control Box	Overall: 11-3/4"L x 11-3/4"W x 3-1/4"H Cut Box: 10-1/2"L x 10-1/2"W Control box: 5-3/4" x 2-5/8"

IND-D120V



IND-DR120V



NEMA 5-15 PLUG
120V/15 Amps



ADCRAFT®

Protected by Admiral Craft Equipment Corporation's one year limited warranty. Should your product fail under normal use, it will be repaired or replaced up to one year from date of purchase.



The more you look, the better we look.



Wok Induction Cookers

IND-WOK120V
IND-WOK208V

- Constructed of heavy duty stainless steel and ceramic glass
- Self checking automatic shutoff feature
- Safety overheating sensor
- Reaches temperature up to 464°F
- 180 minute adjustable timer
- Wall stopper included
- Induction ready wok (IND-WOK) sold separately
- CE, FCC

IND-WOK
sold separately



Item Number Name	Power Usage	NEMA Plug
IND-WOK120V Wok Induction cooker	120V/60hz 1800W, 15Amps	5-15  <small>NEMA 5-15 PLUG 120V/15 Amps</small>
IND-WOK208V Wok Induction cooker	208V/60hz 3000W, 14.4 Amps	6-20  <small>NEMA 6-20 PLUG 208V, 14.4 Amps</small>

CE FCC

ADCRAFT®

Protected by Admiral Craft Equipment Corporation's one year limited warranty. Should your product fail under normal use, it will be repaired or replaced up to one year from date of purchase.



The more you look, the better we look.

Meat Grinders

MG-1
MG-1.5

- Body is constructed of cast aluminum
- Comes complete with stainless steel t-head, screws, propellor and grinder plate
- Overload protection and reverse function
- ETL Listed and ETL Sanitation

Item Number	Grinder Head	Horsepower	Voltage	Wattage	Amps
MG-1	#12	1 HP	120V	745W	6
MG-1.5	#22	1.5 HP	120V	1000W	8



ADCRAFT®

NEMA 5-15 PLUG
120V/15 Amps



Protected by Admiral Craft Equipment Corporation's one year limited warranty. Should your product fail under normal use, it will be repaired or replaced up to one year from date of purchase.



The more you look, the better we look.

Pizza Oven

PO-18

- Perfect for use in kitchens with limited space
- Oven comes with two removable ceramic hearth baking shelves with a 3-1/4" deck height
- Ideal for making pizza, breads and other bakery products
- Thermostat range of 284°F to 680°F
- 15 minute continuous timer
- 6 foot power cord
- Unit dimensions: 23"W x 25"D x 21"H
- 240V/50-60hz, 2850W, 12 amps

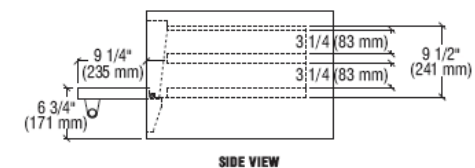
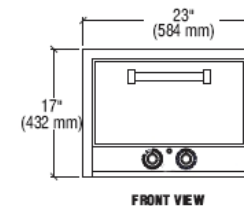
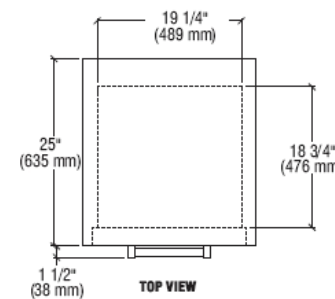

NEMA 6-20 PLUG
208V, 240V/15 Amps



SHIPPING INFORMATION

Model	Lbs.	Kilos	Length	Width	Height*	Cubic Feet	Cubic Meter
PO-18	146	66	25	23	21	6.92	0.196

*Legs not pictured

ADCRAFT®

Protected by Admiral Craft Equipment Corporation's one year limited warranty. Should your product fail under normal use, it will be repaired or replaced up to one year from date of purchase.



The more you look, the better we look.

Pizza Oven

- Perfect for use in kitchens with limited space
- Oven comes with two removable ceramic hearth baking shelves with a 3-1/4" deck height
- Ideal for making pizza, breads and other bakery products
- Thermostat range of 284°F to 680°F
- 15 minute continuous timer
- 6 foot power cord
- Unit dimensions: 26"W x 28"D x 21"H
- 240V/50-60hz, 3600W, 15 amps

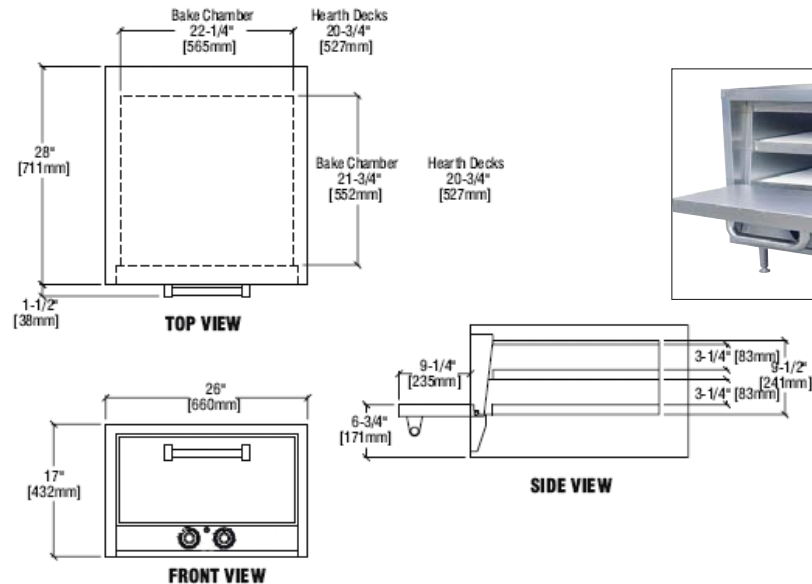

SHIPPING INFORMATION							
Model	Lbs.	Kilos	Length	Width	Height*	Cubic Feet	Cubic Meter
PO-22	178	81	28	26	21	8.75	0.248

*Legs not pictured

NEMA 6-20 PLUG
208V, 240V/15 Amps



Protected by Admiral Craft Equipment Corporation's one year limited warranty. Should your product fail under normal use, it will be repaired or replaced up to one year from date of purchase.



Pizza Merchandisers

Vitrinas para Pizza

PW-16
PW-20

- Great for merchandising pizza and other hot food items
Excelente para comercialización de pizza y otros alimentos calientes
- Constructed of heavy duty stainless steel
Construido de acero inoxidable de alta resistencia
- Heated shelves hold pizzas up to 16" and 20"
Bandejas calientes acomodan pizzas hasta 16" y 20"
- Internal temperature range of 86°F-185°F
Rango interior de temperatura de 86°F - 185°F
- Interior thermometer for easy viewing of temperature
Termómetro interior con fácil lectura de la temperatura
- Illuminated interior
Interior Iluminado
- Optional red plastic top includes graphics to enhance impulse purchases (PW-16/TOP & PW-20/TOP)
Opcional cubierta plástica roja incluye gráficos que promueven compras de impulso (PW-16/TOP & PW-20/TOP)
- CE



Optional red top (PW-16/TOP and PW-20/TOP) includes colorful graphics to help enhance impulse purchases



Item Number	Overall Dimensions	Shelf Dimensions	Net Weight	Gross Weight	Voltage	Wattage	Amps
PW-16	19" x 19" x 20.5"	17" x 17"	45 lbs	47.25 lbs	120V	375W	3
PW-20	23" x 23" x 20.5"	21" x 21"	61.75 lbs	66 lbs	120V	535W	4.5

ADCRAFT®

NEMA 5-15 PLUG
120V/15 Amps



Protected by Admiral Craft Equipment Corporation's one year limited warranty. Should your product fail under normal use, it will be repaired or replaced up to one year from date of purchase.



The more you look, the better we look.

Premium Rice Cooker

Olla Arrocera

RC-0030

- Heavy duty professional quality
Usa industrial y calidad profesional
- 30 Cup capacity
30 tazas de capacidad
- Includes stainless steel lid with clear viewing top
Incluye tapa de acero inoxidable con una clara visión
- Aluminum interior
Interior de aluminio
- Comes complete with oversized plastic fork and clear plastic measuring cup
Tenedor de plástico de gran tamaño y taza de plástico de medicion
- Keep warm feature
Función de mantener caliente
- 110-120V, 1650-1800W, 15 Amps
- CE, ETL Listed, UL



NEMA 5-15 PLUG
120V/15 Amps



Protected by Admiral Craft Equipment Corporation's one year limited warranty. Should your product fail under normal use, it will be repaired or replaced up to one year from date of purchase.



ADCRAFT®





The more you look, the better we look.

Economy Rice Cookers

Ollas Arroceras

RC-E25
RC-E30
RC-E50

- Heavy duty professional quality
Uso industrial y calidad profesional
- Includes stainless steel lid
Incluye tapa de acero inoxidable
- Aluminum interior
Interior de aluminio
- Comes complete with oversized plastic fork and clear plastic measuring cup
Tenedor de plástico de gran tamaño y taza de plástico de medicion
- Keep warm feature
Función de mantener caliente
- CE

Item Number	Cup Capacity	Voltage	Wattage	Amps	NEMA Plug
RC-E25	25 cups	120V	1550W	13	5-15 
RC-E30	30 cups	120V	1650W	14.5	5-15 
RC-E50	50 cups	208V/240V	2630-3500W	14.5	6-20 



ADCRAFT

CE

Protected by Admiral Craft Equipment Corporation's one year limited warranty. Should your product fail under normal use, it will be repaired or replaced up to one year from date of purchase.



The more you look, the better we look.

Roller Grills

Parrilla de Rodillos

RG-05
RG-07
RG-09

- Heavy duty 304 stainless steel construction
Uso industrial y construcción en acero inoxidable 304
- High torque motor provides durability and low maintenance
Motor de alto par proporciona durabilidad y bajo mantenimiento
- RG-07 and RG-09 models have controls for front and back rollers
Modelos RG-07 y RG-09 tiene controles para los rodillos de delante y por detrás
- Sneeze guards available
Cubre estornudos disponible
- NSF



RG-05



RG-07



RG-09



Sneeze Guard
Sold Separately

Item Number	Dimensions	Rollers	Voltage	Wattage	Amps	Sneeze Guard
RG-05	22-1/2" x 8-1/2" x 8"	5 Rollers 12 hot dogs	120V	400W	3.3	RG-05/COV
RG-07	22-1/2" x 12" x 8"	7 Rollers 18 hot dogs	120V	560W	4.6	RG-07/COV
RG-09	22-1/2" x 15-1/3" x 8"	9 Rollers 24 hot dogs	120V	720W	6	RG-09/COV

ADCRAFT

NEMA 5-15 PLUG
120V/15 Amps



Protected by Admiral Craft Equipment Corporation's one year limited warranty. Should your product fail under normal use, it will be repaired or replaced up to one year from date of purchase.



The more you look, the better we look.

RW-E50

Rice Warmer

Calentador de Arroz

- Constructed of heavy duty stainless steel
Construido de pesado acero inoxidable
- Serves 50 cups or 100 bowls
Capacidad de 50 tazas
- Non-stick inner pot
Olla con interior antiadherente
- Easy to open and close lid
Tapa fácil de abrir y cerrar
- Solid and durable handles for easy transport
Sólida y durables manijas para fácil transportacion
- Complete with oversized plastic spatula
Incluye espátula plástico de gran tamaño
- Keeps rice warm for up to 12 hours after its cooked
Mantiene el arroz caliente hasta un maximo de 12 horas después de cocinado
- Overall dimensions: 15-1/2"H x 18-1/2"W x 14-3/4"D
Medidas 15-1/2"H x 18-1/2"W x 14-3/4"D
- 120V, 100W, 0.83 Amps
- CE



NEMA 5-15 PLUG
120V/15 Amps



ADCRAFT®

CE

Protected by Admiral Craft Equipment Corporation's one year limited warranty. Should your product fail under normal use, it will be repaired or replaced up to one year from date of purchase.



The more you look, the better we look.

Sandwich Grills

Parrillas para Sandwiches

SG-811
SG-811/F

- Heavy duty professional quality
Usa industrial y calidad profesional
- Stainless steel construction
construcción de acero inoxidable
- Available in grooved or flat cast iron plates
Disponible en planchas de hierro acanaladas o planas fundido
- Thermostat control range of 120° to 570°F
Rango de control del termostato de 120°-570°F
- Includes oil tray and cleaning brush
Incluye cepillo para limpieza y recolector de aceite removible
- Cooking surface measures 8.5" x 9.25"
Superficie de cocción mide 8.5 "x 9.25"
- 120V, 1750W, 14.5 Amps
- NSF

SG-811
Grooved Plates



SG-811/F
Flat Plates



NEMA 5-15 PLUG
120V/15 Amps



Protected by Admiral Craft Equipment Corporation's one year limited warranty. Should your product fail under normal use, it will be repaired or replaced up to one year from date of purchase.



ADCRAFT®



The more you look, the better we look.

Panini Grills

Parrillas para Paninis

SG-811E
SG-811E/F

- Heavy duty professional quality
Usa industrial y calidad profesional
- Stainless steel construction
construcción de acero inoxidable
- Available in grooved or flat cast iron plates
Disponible en planchas de hierro acanaladas o planas fundido
- Thermostat control range of 120° to 570°F
Rango de control del termostato de 120°-570°F
- Includes oil tray and cleaning brush
Incluye cepillo para limpieza y recolector de aceite removible
- Cooking surface measures 13.25" x 9.25"
Superficie de cocción mide 13.25 "x 9.25"
- 120V, 1750W, 14.5 Amps
- CE, NSF

SG-811E
Grooved Plates



SG-811E/F
Flat Plates



ADCRAFT®

NEMA 5-15 PLUG
120V/15 Amps



Protected by Admiral Craft Equipment Corporation's one year limited warranty. Should your product fail under normal use, it will be repaired or replaced up to one year from date of purchase.



The more you look, the better we look.

Double Sandwich Grill

Parrillas para Sandwich Doble

SG-813

- Heavy duty professional quality
Usa industrial y calidad profesional
- Stainless steel construction
construcción de acero inoxidable
- Two separate grooved cast iron grilling plates
Disponible en planchas de hierro acanaladas o planas fundido
- Each grill plate has its own control switch and power cord
Cada placa de la parrilla tiene su propio interruptor de control y cable de alimentación
- Thermostat control range of 120° to 570°F
Rango de control del termostato de 120°-570°F
- Includes oil tray and cleaning brush
Incluye cepillo para limpieza y recolector de aceite removible
- Cooking surface measures 19" x 9.25"
Superficie de cocción mide 19 "x 9.25"
- 120V, 1750-3500W, 14.5 Amps (per side)
- NSF



ADCRAFT®

NEMA 5-15 PLUG
120V/15 Amps



Protected by Admiral Craft Equipment Corporation's one year limited warranty. Should your product fail under normal use, it will be repaired or replaced up to one year from date of purchase.



The more you look, the better we look.

Premium Soup Kettle

Sopa de prima Hervidor

SK-500W

- Scratch and dent resistant high impact plastic exterior
Plástico resistente de alto impacto exterior
- Heavy duty stainless steel insert and lid
Acero inoxidable de alta resistencia tapa y container
- Holds 11.4 quarts of liquid
Capacidad 11.4 litros
- Temperature ranges from 80° to 200°F
Lecturas de temperatura 80°-200°F
- Infinite control switch
Infinito cambiar
- 120V, 500W, 4 Amps
- CE, ETL Listed



NEMA 5-15 PLUG
120V/15 Amps



Protected by Admiral Craft Equipment Corporation's one year limited warranty. Should your product fail under normal use, it will be repaired or replaced up to one year from date of purchase.



ADCRAFT®



The more you look, the better we look.

Economy Soup Kettle

Sopa de Economía Caldera

SK-600

- Available in black powder shell
Disponible en polvo de cáscara de negro
- Holds up to 11 quarts of liquid
Tiene hasta 11 litros de líquido
- Adjustable temperature control
Control ajustable de temperatura
- Complete with hinged lid and insert
Incluye tapa con agarradera y inserto
- 110V, 400W, 3.6 Amps
- ETL Listed, ETL Sanitation



NEMA 5-15 PLUG
120V/15 Amps



Protected by Admiral Craft Equipment Corporation's one year limited warranty. Should your product fail under normal use, it will be repaired or replaced up to one year from date of purchase.



ADCRAFT®



The more you look, the better we look.

WP-2

Warmer Plate

Placa Calentadora

- Durable yet lightweight stainless steel construction
Construcción duradera y aún ligera de acero inoxidable
- Separate easy to see on/off light for each warmer
Luz de encendido/apagado separada y fácil de ver para cada calentador
- Two porcelain warmers position coffee pots securely
Dos calentadores de porcelana acomodan jarras de café seguramente
- 120V, 500W, 4 Amps
- ETL, UL EPH



NEMA 5-15 PLUG
120V/15 Amps



Protected by Admiral Craft Equipment Corporation's one year limited warranty. Should your product fail under normal use, it will be repaired or replaced up to one year from date of purchase.



ADCRAFT®



The more you look, the better we look.

Specifications

Description

Adcraft's Countertop Warmers and Cookers are constructed with a heavy duty stainless steel exterior and have a stainless steel interior liner made out of 20 gauge 18/8 stainless steel. Designed with a steel element support that stabilizes the heating elements giving off an even heat distribution with no hot spots. These units maintain food temperatures in excess of 140°F to meet the requirements for food safety. Easy to clean, lightweight and they each come with an adjustable thermostat knob. The FW-1500W/C has a thermostatic range that reaches 212°F making it great for defrosting and slow cooking meats. These units will preheat quickly to 180°F in around 12 minutes. They are 120V and come with a 5' power cord with a NEMA 5-15 plug. These units are UL and NSF approved and are backed by Adcraft's 18 month warranty.

Construction

- Commercial quality heavy duty stainless steel construction
- Interior well is constructed of heavy duty 20 gauge 18/8 stainless steel
- Steel element support stabilizes heating elements and reflects heat toward food providing even heat distribution
- 6.5" deep well can accommodate food pans up to 4" deep

Operation

- Adjustable heating control allows for keeping food warm at a desired temperature for an extended period of time
- Maintains food temperature in excess of 140°F
- Adjustable temperature range up to 212°F on the FW-1500W/C model allows to be used as a slow cooker also

Electrical

- 5' power cord with NEMA 5-15 plug

Accessories (Sold Separately)

- AB-12 - 12" x 1" Adapter Bar
- AB-20 - 20" x 1" Adapter Bar
- SAP-88 - Adapter Plate - 2 Hole
- SAP-566 - Adapter Plate - 3 Hole

Certifications/Approvals



Countertop Warmers and Cookers

Models:

- FW-1200W - Full Size Warmer
- FW-1500W - 4/3 Size Warmer
- FW-1500W/C - Full Size Cooker/Warmer



FW-1200W



FW-1500W



FW-1500W/C

Warranty: This product is protected by Admiral Craft Equipment Corporation's 18 month limited warranty. Should your product fail under normal use it will be repaired or replaced up to 18 months from date of purchase.



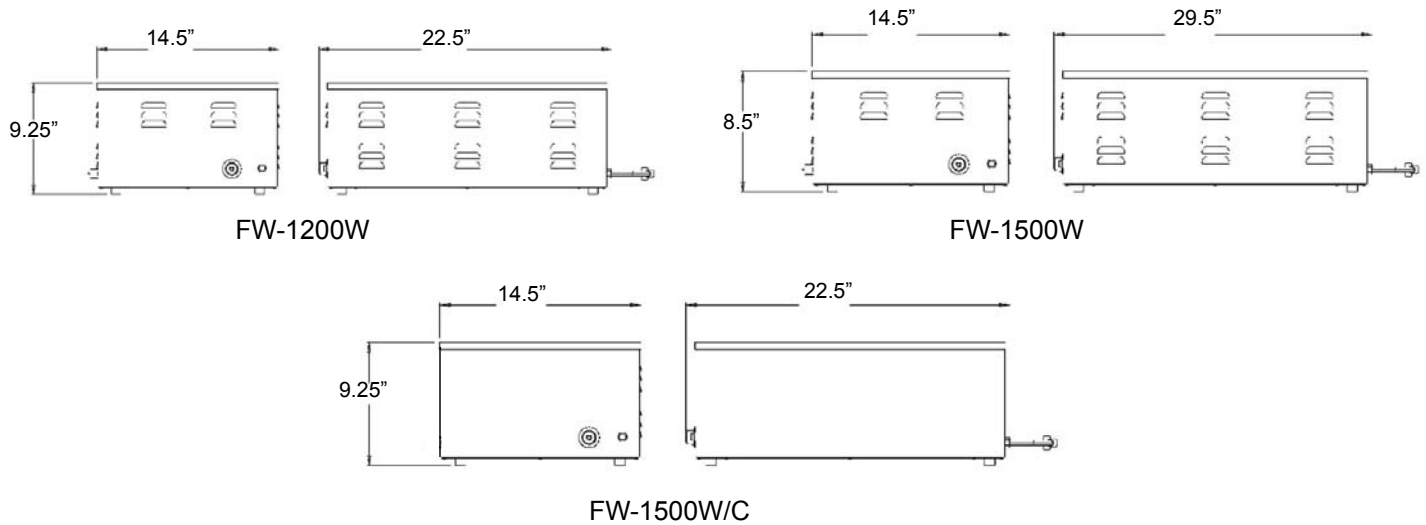

Countertop Warmers and Cookers - FW-1200W, FW-1500W, FW-1500W/C

Plan View



Specifications

Item Number	Description	Volts	Wattage	Amps	NEMA Plug
FW-1200W	Full Size Food Warmer	120V	1200W	10	5-15P 
FW-1500W	4/3 Size Food Warmer	120V	1500W	12.5	5-15P 
FW-1500W/C	Full Size Cooker/Warmer	120V	1500W	12.5	5-15P 

Item Number	Item Dimensions	Pan Opening	Temperature Range	Pre-Heat Time to 180°F
FW-1200W	14.5"W x 22.25"D x 9.25"H	12" x 20"	120° - 190°F	12 minutes
FW-1500W	14.5"W x 29.5"D x 8.5"H	12" x 27"	120° - 190°F	14 minutes
FW-1500W/C	14.5"W x 22.25"D x 9.25"H	12" x 20"	120° - 212°F	10 minutes

Shipping Info

Item Number	Box Dimensions	Gross Weight	Net Weight
FW-1200W	16"W x 25"D x 10"H	19 lbs	17 lbs
FW-1500W	16"W x 32"D x 10"H	23 lbs	19 lbs
FW-1500W/C	16"W x 25"D x 10"H	19 lbs	17 lbs

For more information about this or any of our other products go to www.admiralcraft.com. These items are listed on AutoQuotes. For full explanation of warranty coverage on this product please refer to warranty page located in the owner's manual and warranty section at www.admiralcraft.com. Specifications subject to change without notice. Please confirm at time of order.

Specifications

Description

Adcraft's 7/11 quart round cooker/warmers are constructed with a stainless steel interior liner made of out of 20 gauge 18/8 stainless steel . They are can be used as a slow cooker or a food warmer. They have a manual temperature control knob that has a range of 0°F-212°F. The included adaptor ring easily converts these items from 11 qt to 7 qt with the use of a smaller inset (Insets not included). 120V, 1200W, 10 Amps. NEMA 5-15 plug. These units are UL and UL EPH and backed by Adcraft's 1 year limited warranty.

Construction

- Interior liner is constructed of heavy duty 20 gauge 18/8 stainless steel
- Available in stainless steel or matte black finish
- Non-slip bakelite feet for stability

Operation

- Adjustable heating control allows for keeping food warm at a desired temperature for an extended period of time
- Min/Max line on the inside for accurate measurement of water
- Easily convert from 11 qts to 7 qts in no time with the stainless steel adapter ring (Included)
- Pre-heat in only 30 minutes.

Electrical

- 120V, 1200W, 10 Amps
- 5' power cord with NEMA 5-15 plug

Accessories (Sold Separately)

- SVI-105 - 11 quart stainless steel inset
- SVI-85 - 7 quart stainless steel inset

Certifications/Approvals



7/11 Qt. Round Cooker/Warmers

Models:

- FW-1200WR
- FW-1200WR/B

FW-1200WR



FW-1200WR/B
Shown with adapter ring



Easily convert this round cooker/warmer from a 11 quart inset holder to a 7 quart inset holder with the included stainless steel adapter ring.

Warranty: This product is protected by Admiral Craft Equipment Corporation's one year limited warranty. Should your product fail under normal use it will be repaired or replaced up to one year from date of purchase.





Date: _____
 Item No.: _____
 Project No.: _____

7/11 Qt. Round Cooker/Warmers - FW-1200WR, FW-1200WR/B

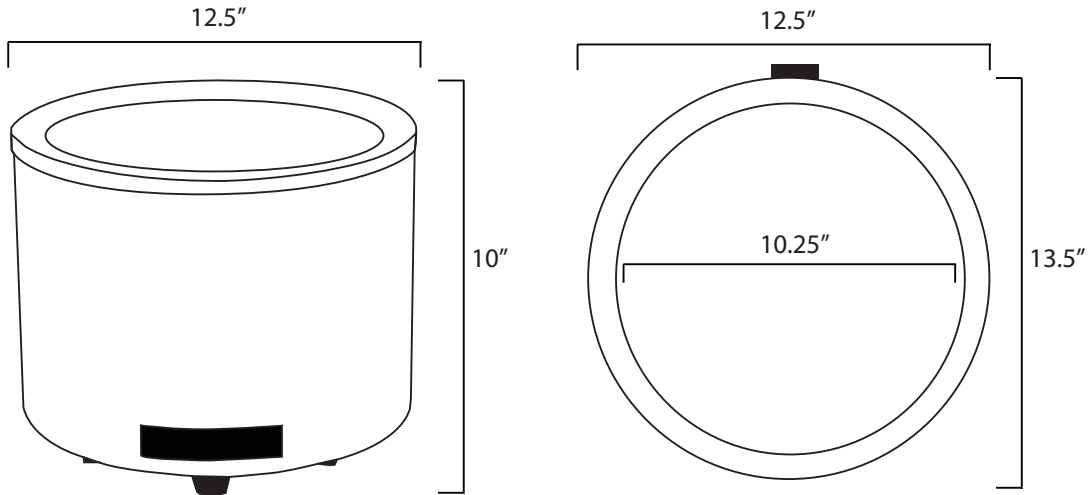
Plan View



Specifications

Item Number	Item Dimensions	Volts	Wattage	Amps	NEMA Plug
FW-1200WR	12.5"W x 13.5"D x 10"H	120V	1200W	10	5-15P 
FW-1200WR/B	12.5"W x 13.5"D x 10"H	120V	1200W	10	5-15P 

Shipping Info

Item Number	Box Dimensions	Gross Weight	Net Weight
FW-1200WR	14"W x 14"D x 12"H	12 lbs	10 lbs
FW-1200WR/B	14"W x 14"D x 12"H	12 lbs	10 lbs

For more information about this or any of our other products go to www.admiralcraft.com. These items are listed on AutoQuotes. For full explanation of warranty coverage on this product please refer to warranty page located in the owner's manual and warranty section at www.admiralcraft.com. Specifications subject to change without notice. Please confirm at time of order.

Specifications

Description

Adcraft's stainless steel airpot and thermal server coffee brewers will brew up to 3.8 gallons of hot coffee per hour. Constructed with a stainless steel tank and body that gives them a great commercial look and makes them easy to clean. Brew directly into the airpots and thermal servers quickly with just a simple push of a button. The black plastic funnel and non-slip base provide for a safe and accurate pour every-time. 120V, 1450W, 12 Amps. NEMA 5-15 plug. These units are ETL Listed and ETL Sanitation. Airpots and servers sold separately. They are backed by Adcraft's 1 year warranty.

Construction

- All stainless steel construction
- Stainless steel tank holds up to 2.2 liters of water
- Direct feed hook up for non-stop flow of coffee (water line required)
- Non-slip base and guides for safe and accurate filling
- Non-slip rubber feet for stability

Operation

- Easy to use push button brewing allows for continuous flow of coffee
- Lighted on/off power switch
- Indicator lights let you know when the unit is filling and ready to pour
- UB-289 fits airpots up to 14" tall
- UB-286 fits carafes and servers up to 10" tall

Electrical

- 120V, 1450W, 12 Amps
- 4' power cord with a NEMA 5-15 plug

Accessories (Sold Separately)

Stainless Steel Airpots

- APL-19 - 1.9L s/s airpot
- APL-22 - 2.2L s/s airpot
- APL-25 - 2.5L s/s airpot
- APL-30 - 3L s/s airpot

Stainless Steel Servers

- SLVF-750 - 750ML s/s server
- SLVF-1000 - 1000ML s/s server
- SLVF-1500 - 1500ML s/s server

For a full list of all Adcraft airpots and thermal servers visit our website at <http://admiralcraft.com/product-category/smallwares/tabletop/beverage-dispensers/>

Certifications/Approvals



Coffee Brewers - Airpots/Servers Direct Feed

Models:

- UB-286 - Thermal Servers
- UB-289 - Airpots



UB-286



UB-289

Warranty: This product is protected by Admiral Craft Equipment Corporation's one year limited warranty. Should your product fail under normal use it will be repaired or replaced up to one year from date of purchase.





Date: _____
 Item No.: _____
 Project No.: _____

Coffee Brewers - Direct Feed, Airpots and Servers UB-286 and UB-289

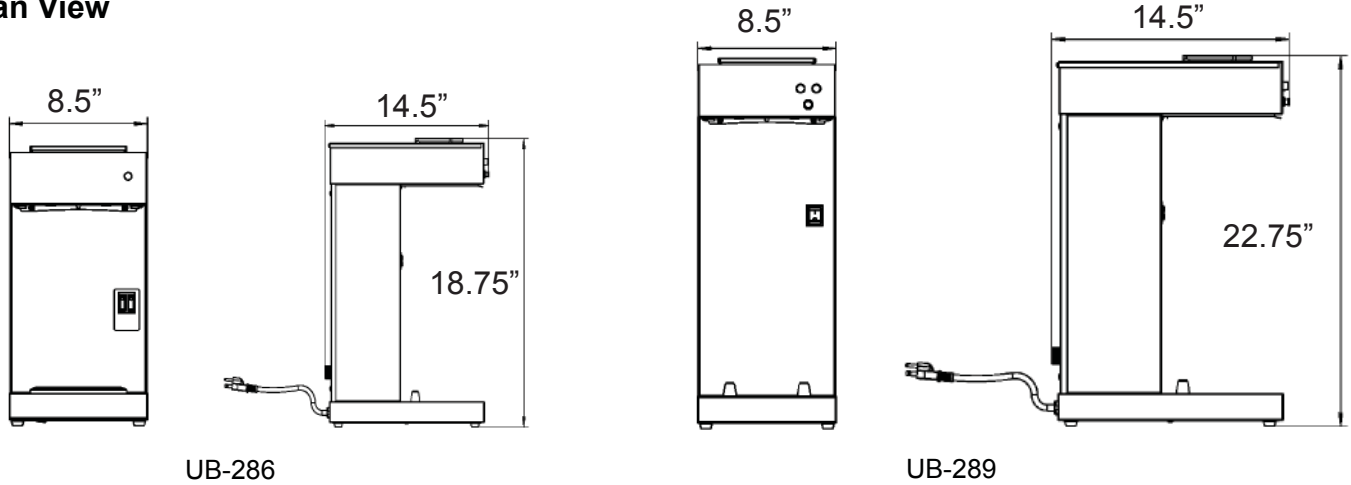
Plan View



Specifications

Item Number	Item Dimensions	Volts	Wattage	Amps	NEMA Plug
UB-286	8.5"W x 14.5"D x 18.75"H	120V	1450W	12	5-15P 
UB-289	8.5"W x 14.5"D x 22.75"H	120V	1450W	12	5-15P 

Shipping Info

Item Number	Box Dimensions	Gross Weight	Net Weight
UB-286	11"W x 19"D x 21.5"H	24 lbs	21 lbs
UB-289	11"W x 19"D x 25"H	25 lbs	22 lbs

For more information about this or any of our other products go to www.admiralcraft.com. These items are listed on AutoQuotes. For full explanation of warranty coverage on this product please refer to warranty page located in the owner's manual and warranty section at www.admiralcraft.com. Specifications subject to change without notice. Please confirm at time of order.

Specifications

Description

Adcraft's stainless steel water boilers are ideal for any institution, church, cafeteria, etc. All parts are constructed of durable stainless steel and each unit is equipped with a clear water level gauge. The bottom of the unit has an extra large encapsulated heating element that is waterproof and distributes heat evenly throughout. A variable temperature control knob and heat resistant side handles come standard on each unit. An illuminated power switch lights up to let you know when the unit is in use. 120V, 1350W, 11.25 Amps. 3' power cord with NEMA 5-15 plug. ETL Listed and ETL Sanitation. This item is backed by Adcraft's 1 year limited warranty.

Construction

- All stainless steel construction inside and out
- Extra large encapsulated heating element for fast and even heating
- Cool to touch bakelite handles for easy transporting
- Available in 40 cup and 100 cup quantities

Operation

- Variable temperature control knob ranges from 85°-230°F
- Easy to read clear water level gauge with quick pour spigot
- Illuminated power switch and indicator

Electrical

- 120V, 1350W, 11.25 Amps
- 3' power cord with NEMA 5-15 plug

Model Features

- Non-slip rubber feet for stability
- Also great for keeping sauces such as Au Jus, barbeque sauce and other hot beverages warm for an extended period of time

Commercial Water Boilers

Models:

- WB-100
- WB-40



Certifications/Approvals



Warranty: This product is protected by Admiral Craft Equipment Corporation's one year limited warranty. Should your product fail under normal use it will be repaired or replaced up to one year from date of purchase.



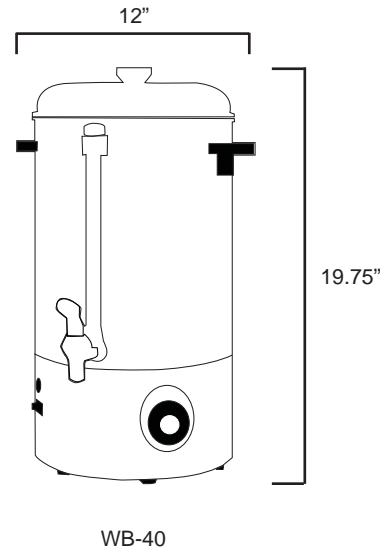
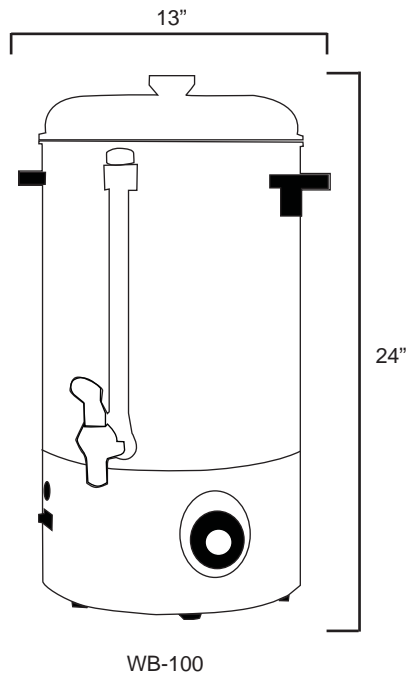

Commercial Water Boilers - WB-100, WB-40

Plan View



Specifications

Item Number	Description	Cup Capacity	Volts	Wattage	Amps	NEMA Plug
WB-100	100 Cup Water Boiler	100 cups	120V	1350W	11.25	5-15P 
WB-40	40 Cup Water Boiler	40 cups	120V	1350W	11.25	5-15P 

Shipping Info

Item Number	Box Dimensions	Item Dimensions	Gross Weight	Net Weight
WB-100	12.5"W x 13"D x 23"H	13"W x 13.5"D x 24"H	12 lbs	10 lbs
WB-40	11.5"W x 11.5"D x 18.75"H	12"W x 12"D x 19.75"H	8.5 lbs	7 lbs

For more information about this or any of our other products go to www.admiralcraft.com. This item is listed on AutoQuotes. For full explanation of warranty coverage on this product please refer to warranty page located in the owner's manual and warranty section at www.admiralcraft.com. Specifications subject to change without notice. Please confirm at time of order.

Specifications

Description

Adcraft's manual gravity feed slicers are constructed of high quality anodized aluminum which makes them extremely durable and easy to clean. Perfect for slicing vegetables and lunch meats. Their small footprint and compact design make them ideal for delis, sub shops and small restaurants. Each model comes with a removable carriage for easy cleanup and a built in sharpener to always ensure a sharp edge for every slice. The blades have a permanently attached ring guard around them for safety. The motors are belt driven and each unit is 110V with a NEMA 5-15 plug. These items are all ETL Certified and backed by Adcraft's one year replace or repair warranty policy.

Construction

- Constructed of high quality anodized aluminum
- Stainless steel blade lasts long and is easy to sharpen
- Top mounted metal sharpener comes with two grinding stones
- Removable carriage for easy cleaning
- Permanently attached ring guard for safe operating
- Non slip rubber feet keeps the slicer steady and in place

Operation

- Slicers blades are belt driven for a smooth and effortless cut
- Carriage ball bearings are lubricated for quiet operation
- Adjustable knob allows for precise slicing up to 1/2" thick
- On/Off buttons are enclosed to keep out moisture

Electrical

- Electrical components are enclosed below the unit keeping them clear of food and other debris
- 110V electrical connection
- 4' power cord with NEMA 5-15 plug

Usage

- Light duty slicers are ideal for low volume applications with less than 1 hour of slicing per day. These items are not meant for cutting raw or frozen meat and/or cheese.
- Medium duty slicer is ideal for several hours of slicing per day. Slicing raw or frozen meat is not recommended for this item. A maximum of 30 minutes a day of cheese slicing is recommended for this item.

Manual Gravity Feed Slicers

Models:

- SL250ES-10
- SL300ES
- 300ES-12
- SL300C



SL250ES-10



SL300ES and 300ES-12



SL300C

Certifications/Approvals



Warranty: This product is protected by Admiral Craft Equipment Corporation's 1 year limited warranty. Should your product fail under normal use it will be repaired or replaced up to 1 year from date of purchase.



Manual Gravity Feed Slicers - SL250ES-10, SL300ES, 300ES-12, SL300C

Plan View

SL250ES-10

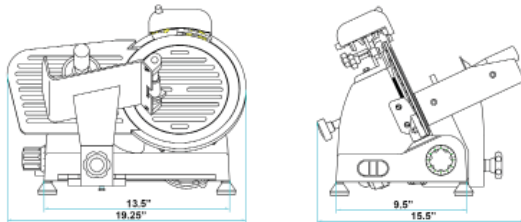



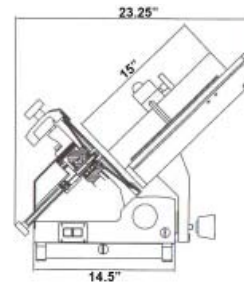
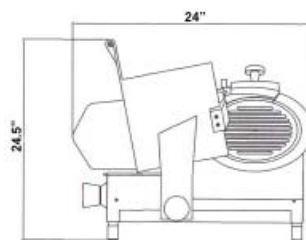
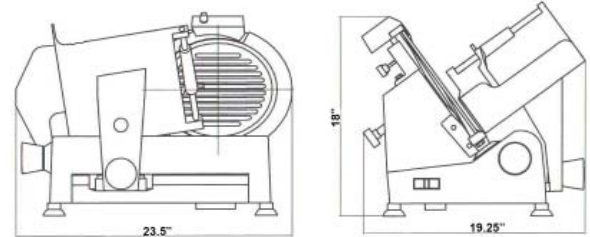

SL300ES and 300ES-12



SL300C

Specifications

Item Number	Description	Blade Diameter	Horsepower	Volts	NEMA Plug
SL250ES-10	10" Light Duty Meat Slicer 1/4HP	10"	1/4 HP	110V	5-15P 
SL300ES	12" Light Duty Meat Slicer 1/3 HP	12"	1/3 HP	110V	5-15P 
300ES-12	12" Medium Duty Meat Slicer 1/2 HP	12"	1/2 HP	110V	5-15P 
SL300C	12" Medium Duty HT Meat Slicer 1/2 HP	12"	1/2 HP	110V	5-15P 

Item Number	Cut Capacity	Max Cut Thickness	Blade Rotation Speed	Usage	Slice Cheese
SL250ES-10	8" x 6.5"	1/2"	465 RPM	Light Duty	No
SL300ES	9" x 7"	1/2"	428 RPM	Light Duty	No
300ES-12	9" x 7"	1/2"	428 RPM	Medium Duty	No
SL300C	11" x 8"	1/2"	298 RPM	Medium Duty	Yes

Shipping Info

Item Number	Item Dimensions (in)	Shipping Dimensions (in)	Gross Weight	Net Weight
SL250ES-10	19" x 15" x 15"	20.5" x 18.5" x 15.25"	40 lbs	33 lbs
SL300ES	21" x 18" x 18"	25" x 21" x 18.5"	64 lbs	54 lbs
300ES-12	21" x 18" x 18"	25" x 21" x 18.5"	64 lbs	54 lbs
SL300C	25" x 23.5" x 25"	27" x 26.25" x 26.75"	101 lbs	90 lbs

For more information about these or any of our other products go to www.admiralcraft.com. These items are listed on AutoQuotes. For full explanation of warranty coverage on this products please refer to warranty page located in the owner's manual and warranty section at www.admiralcraft.com. Specifications subject to change without notice. Please confirm at time of order.

©2015 Admiral Craft Equipment Corp.

Admiral Craft Equipment Corp.

940 South Oyster Bay Rd. • Hicksville, NY 11801 • P: 800-223-7750 • F: 800-447-7751 • www.admiralcraft.com

Specifications

Description

Adcraft's Adjustable Heated Plate Lowerator is a versatile item that can adjust to hold a variety of plate diameters for any occasion. Two field adjustable tubes enclosed in a stainless steel heated cabinet that can hold up to 80 plates at one time. The adjustable tubes can hold plates up to 8"-12" in diameter and will keep them pleasantly warm to help keep food hotter for a longer period of time. 4" casters allow for easy mobility and transporting. The clean stainless steel enclosed cabinet make this a perfect item for front and back of the house operations. This unit is backed by Adcraft's one year replace or repair warranty.

Construction

- Stainless steel frame and construction
- Two adjustable dish dispensing tubes with support rack that can hold plates 8"-12" in diameter
- 4" swivel casters for mobility
- Bakelite handle is cool-to-touch and allows for easy moving

Heated Cabinet

- Single heating element goes throughout the whole cabinet to keep the plates constantly warm while in use
- Interior fan motor circulates the warm air inside the cabinet
- Adjustable thermostat ranges from 85°F - 185°F

Tube Dispensers

- Two stainless steel tubes can hold up to 40 plates each at one time
- Tubes are adjustable and can hold plates from 8"-12" in diameter
- Special support design prevents the plates from sticking in the down position

Electrical

- 120V, 1260W, 10.5 Amps
- 6' power cord with NEMA 5-15 plug

Standard Accessories

- Includes 2 covers that fit over plate holes

Certifications/Approvals

Adjustable Heated Plate Lowerator -2 Tube Dish Dispenser 8"-12"

Models:

- LR-2



Warranty: This product is protected by Admiral Craft Equipment Corporation's 1 year limited warranty. Should your product fail under normal use it will be repaired or replaced up to 1 year from date of purchase.



Adjustable Heated Plate Lowerator 2 Tube Dispenser - LR-2

Plan View

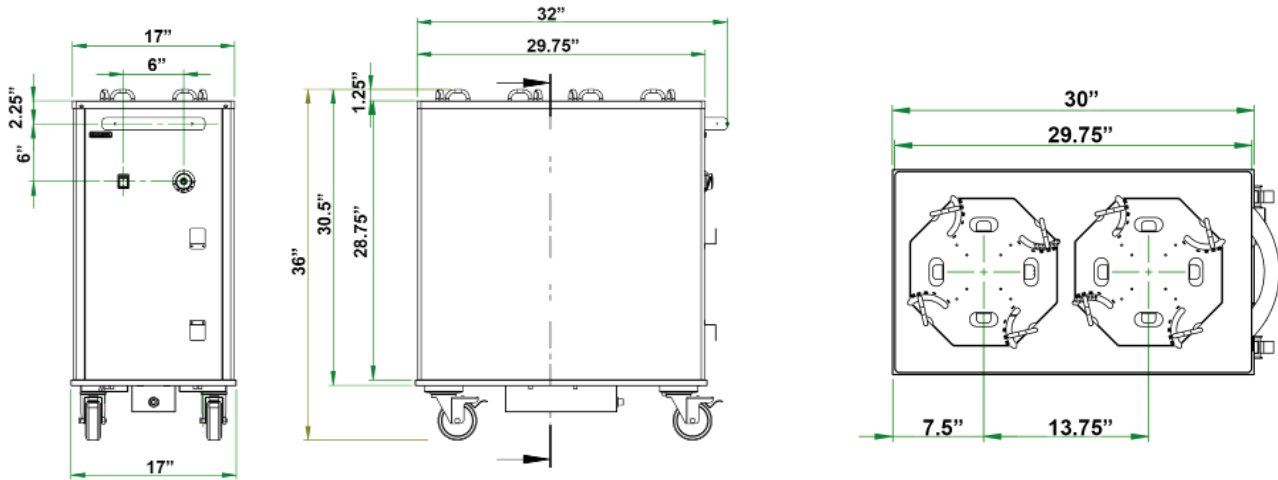

Specifications

Item Number	Description	Tubes	Temperature Range	Volts	Wattage	Amps	NEMA Plug
LR-2	Adjustable Heated Plate Lowerator	2	85° F - 185° F	120V	1260W	10.5	5-15P 

Item Number	Thermostat Range	Tube Capacity (# Plates)	Max Capacity (Lbs)	Cabinet Height
LR-2	Adjustable Heated Plate Lowerator	80	66 lbs	24.5"

Shipping Info

Item Number	Box Dimensions	Item Dimensions	Gross Weight	Net Weight
LR-2	21.5" x 36.5" x 46.5"	16.5" x 31.5" x 36.5"	99 lbs	93 lbs

For more information about this or any of our other products go to www.admiralcraft.com. This items is listed on AutoQuotes. For full explanation of warranty coverage on this product please refer to warranty page located in the owner's manual and warranty section at www.admiralcraft.com. Specifications subject to change without notice. Please confirm at time of order.

Specifications

Description

Adcraft's "Redhead" electric glass washer is made of heavy duty construction with a powerful 1/3 HP motor. It easily removes lipstick and other stains on the glass surface. Quick and easy to install and requires no special plumbing or electrical hook-ups to use. The unit runs off a 115V circuit that draws only 4.3 Amps. Comes complete with four 7" brushes and one 8.75" center brush. Overall dimensions are 19"H x 8.75"W x 15.75"D. CE. This item is backed by Adcraft's 1 year limited warranty.

Base Construction

- Base is made of heavy duty stainless steel with rubber feet for stability
- Brass bearings and nylon gears are inside the base
- Removable rubber strip keeps water out of the base and allows for easy access to gears when needed

Motor

- Powerful 1/3 Horsepower motor mounted up high to keep away from water
- Internal thermal overload in motor prevents overheating if the motor temperature exceeds 150°F
- Front mounted On/Off switch for easy operation when in use

Electrical

- 115V, 1/3 HP, 4.3 Amps
- 7' power cord with NEMA 5-15 plug

Brushes

- Brushes are included with the glass washer and are interchangeable with all other major brand's brushes
- One center brush measures 8.75" tall overall
- Four side brushes measure 7" tall overall

Bar Glass Washer - Upright Non-Submersible

Models:

- GW-120



Certifications/Approvals



Warranty: This product is protected by Admiral Craft Equipment Corporation's one year limited warranty. Should your product fail under normal use it will be repaired or replaced up to one year from date of purchase.



Bar Glass Washer - Upright - GW-120

Plan View

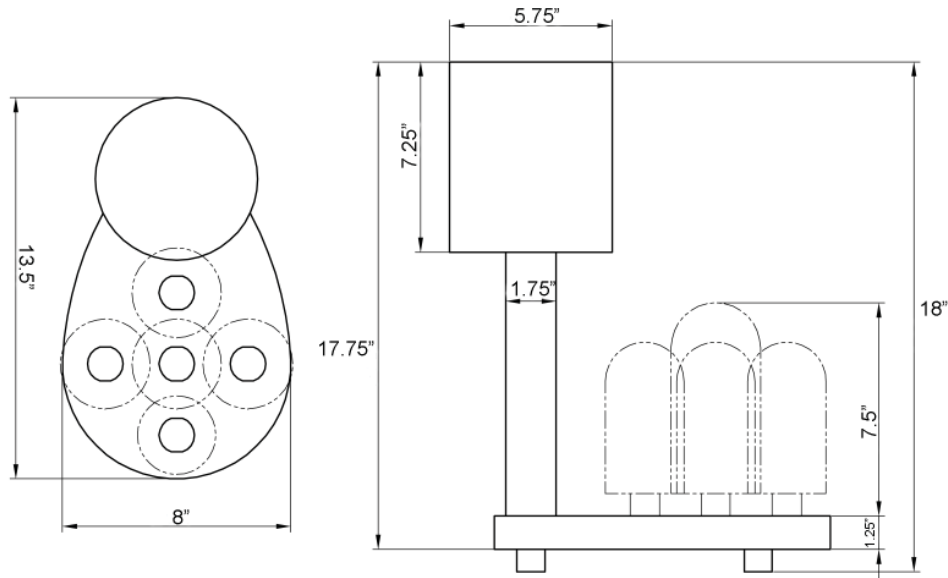

Specifications

Item Number	Description	Volts	Horsepower	Amps	NEMA Plug
GW-120	Redhead Glass Washer	115V	1/3 HP	4.3	5-15P 

Shipping Info

Item Number	Box Dimensions	Item Dimensions	Gross Weight	Net Weight
GW-120	9"W x 16"D x 19"H	8"W x 13.5"D x 18"H	27.5 lbs	25 lbs

For more information about this or any of our other products go to www.admiralcraft.com. This item is listed on AutoQuotes. For full explanation of warranty coverage on this product please refer to warranty page located in the owner's manual and warranty section at www.admiralcraft.com. Specifications subject to change without notice. Please confirm at time of order.

Specifications

Description

Adcraft's HDS-1200W hot dog steamer will steam your hot dogs and buns to perfection every time! The body and lids are constructed of stainless steel and comes with tempered front and rear glass for showcasing. This unit fits 100 standard size hot dogs and 36-48 buns. Steam all day with a 6 quart capacity water pan and adjustable thermostat. The top loading design allows for quick and easy access to the contents. Comes equipped with a front valve drain for easy refilling and disposing of water. 120V, 1200W, 10 Amps and a NEMA 5-15 plug. This item is backed by Adcraft's 1 year replace or repair warranty.

Construction

- Body and lids are constructed of heavy duty stainless steel
- Full view tempered glass on both the operator's and customer's side for merchandising
- Separate hot dog and bun compartment allows the user to control the level of steaming on each side
- Top loading design allows for easy and safe access to your hot dogs and buns

Capacity

- Steams and cooks up to 100 standard sized hot dogs at one time
- Hot dog compartment is 6"W x 12"D x 8"H
- The bun compartment is 11"W x 12"D x 8"H and can hold 36-48 buns
- Water pan holds up to 6 quarts of water for all day steaming

Operation

- Heating system can cook the hot dogs in 20 minutes
- Temperature range of 80°F-185°F
- Humidity control system in bun compartment keeps buns fresh while your hot dogs steam

Electrical

- 120V, 1200W, 10 Amps
- 4' power cord with NEMA 5-15 plug

Features

- Bright and attractive graphics on both sides help get impulse buys
- Front drain and plug for easy disposal of water
- Bakelite knobs on top of the lids for safe opening
- Lighted power switch

Hot Dog Steamer - Top Loading w/Bun Compartment

Models:

- HDS-1200W



Certifications/Approvals

Warranty: This product is protected by Admiral Craft Equipment Corporation's one year limited warranty. Should your product fail under normal use it will be repaired or replaced up to one year from date of purchase.



Date: _____
 Item No.: _____
 Project No.: _____

Hot Dog Steamer - Top Loading w/Bun Compartment - HDS-1200W

Plan View

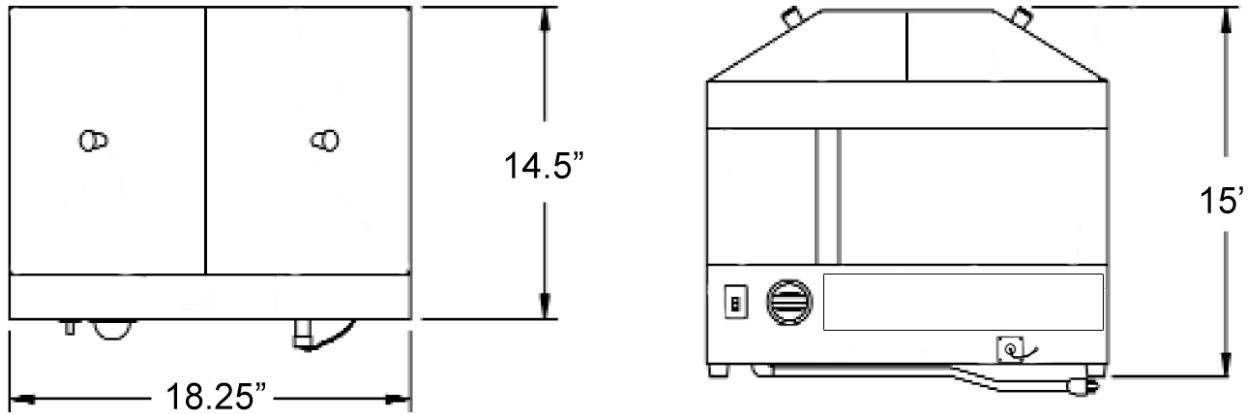

Specifications

Item Number	Description	Volts	Watts	Amps	NEMA Plug
HDS-1200W	Hot Dog Steamer	120V	1200W	10	5-15P 

Shipping Info

Item Number	Box Dimensions	Item Dimensions	Gross Weight	Net Weight
HDS-1200W	21"W x 18"D x 18"H	18.25"W x 14.5"D x 15"H	22 lbs	30 lbs

For more information about this or any of our other products go to www.admiralcraft.com. This item is listed on AutoQuotes. For full explanation of warranty coverage on this product please refer to warranty page located in the owner's manual and warranty section at www.admiralcraft.com. Specifications subject to change without notice. Please confirm at time of order.

Specifications

Description

Adcraft's Infrared Display Warmer is constructed of heavy duty stainless steel. This display warmer can be used in the kitchen as a fried food holding station and in the front of the house to keep hot food on display for an extended period of time as a self serve station. Instead of bulbs, this item uses heating elements that give off a more uniform heat distribution. Polished stainless steel reflectors located above the heating elements help radiate the heat down towards the food zone below. The raised base keeps the food pan off the work area preventing it from getting hot and allows for easy accessibility of the food from all three sides. This display warmer comes complete with a 2" deep full size food pan with removable stainless steel perforated liner for drainage of excess grease. This unit is backed by Adcraft's 1 year limited warranty.

Construction

- Constructed of heavy duty stainless steel
- Fully welded for strong durability
- Raised base keeps food pan off the work area
- Accessible from three sides

Heating

- Heating elements run through the entire top of the unit giving off a more uniform heat distribution eliminating hot and cold spots
- Polished stainless steel reflectors above the heating elements help radiate heat down towards the food zone
- On/Off switch located on the front of the unit away from heat zone

Electrical

- 120V, 940W, 7.8 Amps
- 6' power cord with NEMA 5-15 plug

Model Features

- Includes 2" deep full size food pan with perforated liner for excess grease drainage
- 40 watt light for greater illumination of products

Infrared Display Warmer

Models:

- IDW-940W



Accessories (Sold Separately)

- 22F1 - 2" deep s/s full size food pan
- FB-917 - full size perforated food liner
- FFS-DH - french fry scoop/bagger

Certifications/Approvals

Warranty: This product is protected by Admiral Craft Equipment Corporation's one year limited warranty. Should your product fail under normal use it will be repaired or replaced up to one year from date of purchase.



Infrared Display Warmer - IDW-940W

Plan View

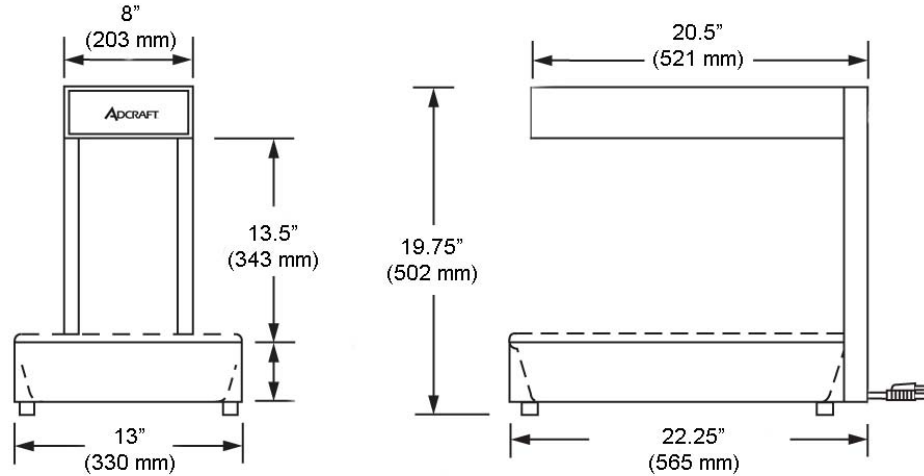

Specifications

Item Number	Item Dimensions	Volts	Wattage	Amps	NEMA Plug
IDW-940W	13"W x 22.5"D x 19.75"H	120V	940W	7.8	5-15P 

Shipping Info

Item Number	Box Dimensions	Gross Weight	Net Weight
IDW-940W	13.75"W x 25"D x 22"H	20 lbs	15.5 lbs

For more information about this or any of our other products go to www.admiralcraft.com. This item is listed on AutoQuotes. For full explanation of warranty coverage on this product please refer to warranty page located in the owner's manual and warranty section at www.admiralcraft.com. Specifications subject to change without notice. Please confirm at time of order.

Specifications

Description

Adcraft's Fresh Shot Countertop Steamer is perfect for keeping tortillas, pitas, bread and so much more hot and fresh at the push of a button. Great for use in any kitchen with its small footprint and compact size. This steamer accommodates one half-size pan. The easy to use push button operation provides a quick shot of heat in seconds that instantly heats up your food. The exterior of the unit is constructed of stainless steel and has a black powder coated top. The interior well is constructed of cast aluminum and is easy to clean. The self contained water reservoir allows for easy filling and disposing of water with no water line hook-up needed. This unit includes a stainless steel perforated half pan, an on/off rocker switch and comes with a 4' power cord with a NEMA 5-15 plug. This item is backed by Adcraft's 1 year limited warranty.

Construction

- Exterior is constructed of heavy duty stainless steel
- Powder coated top
- Cast aluminum well
- Water reservoir holds up to 3 quarts of water

Operation

- Simple one push button that blasts steam in excess of 212°F that rejuvenates and heats up cold, pre-cooked food inside the well.
- Illuminated On/Off rocker switch located on the front of the unit lets you know when the unit is in operation.
- Pre-heat in only 30 minutes.

Electrical

- 120V, 1800W, 15 Amps
- 4' power cord with NEMA 5-15 plug

Model Features

- Includes half size perforated food pan
- Bakelite handle that is cool to touch
- Non-slip rubber feet for stability

Fresh Shot Countertop Steamer

Models:

- CTS-1800W



Certifications/Approvals

Warranty: This product is protected by Admiral Craft Equipment Corporation's one year limited warranty. Should your product fail under normal use it will be repaired or replaced up to one year from date of purchase.



Date: _____
 Item No.: _____
 Project No.: _____

Fresh Shot Countertop Steamer - CTS-1800W

Plan View

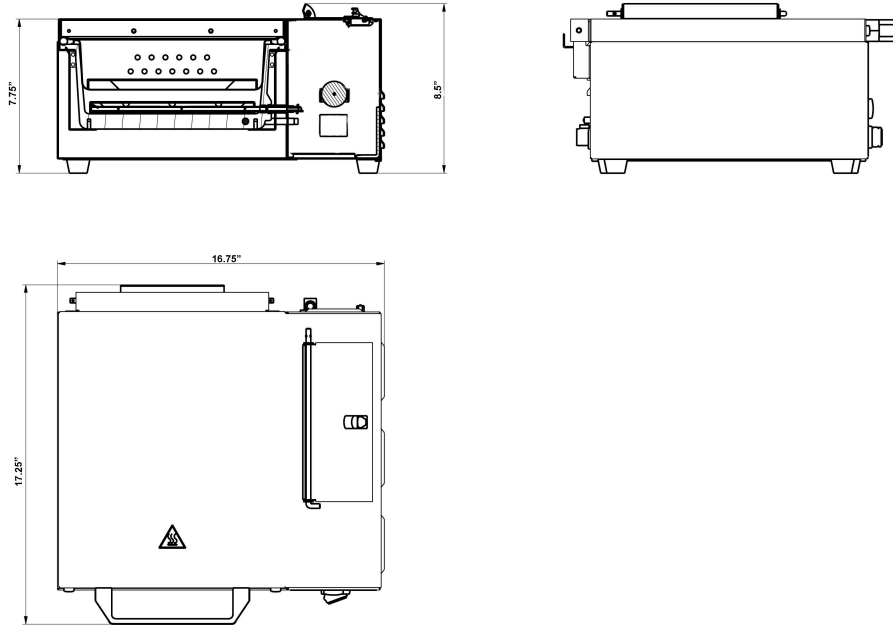

Specifications

Item Number	Item Dimensions	Volts	Wattage	Amps	NEMA Plug
CTS-1800W	16.75"W x 17.25"D x 8.5"H	120V	1800W	15	5-15P 

Overall height with lid open is 24"

Shipping Info

Item Number	Box Dimensions	Gross Weight	Net Weight
CTS-1800W	24"W x 22.5"D x 15.5"H	88 lbs	72.75 lbs

For more information about this or any of our other products go to www.admiralcraft.com. This item is listed on AutoQuotes. For full explanation of warranty coverage on this product please refer to warranty page located in the owner's manual and warranty section at www.admiralcraft.com. Specifications subject to change without notice. Please confirm at time of order.

Specifications

Description

Adcraft's Belgian Waffle Makers are perfect for breakfast spots, diners and any other establishments that wants to add hot and fluffy Belgian waffles to their menu. Cook up to twenty 1.25" thick waffles (per side) per hour with our round 7" single and double Belgian Waffle makers. Constructed with a stainless steel body for durability and easy cleaning. Heavy cast aluminum non-stick coated plates for easy and safe product release. 180 degree rotating hinge for even batter distribution. Easy to set digital timer and temperature controls make using simple enough for everybody. A removable stainless steel drip pan is included for easy cleaning. 120V. 5' long power cord(s) with a NEMA 5-15 plug(s). These units are backed by Adcraft's 1 year warranty.

Construction

- Commercial quality heavy duty stainless steel construction
- Heavy duty non-stick coated aluminum waffle grids
- 500W heating elements in both the top and bottom grids
- Cool to touch bakelite handle
- Removable stainless steel drip tray for easy clean up

Operation

- Adjustable digital timer with buzzer to prevent over cooking
- Adjustable temperature range from 250° to 425°F
- 180° rotating hinge for even batter distribution
- Lighted on/off power switch
- BWM-7/R-2 has individual controls for the time and temperature on each side.

Electrical

- 120V
- 5' power cord(s) with NEMA 5-15 plug(s)
- BWM-7/R-2 comes with 2 power cords

Certifications/Approvals

Belgian Waffle Makers - 7" Round

Models:

- BWM-7/R
- BWM-7/R-2



BWM-7/R



BWM-7/R-2

Warranty: This product is protected by Admiral Craft Equipment Corporation's 1 year limited warranty. Should your product fail under normal use it will be repaired or replaced up to one year from date of purchase.



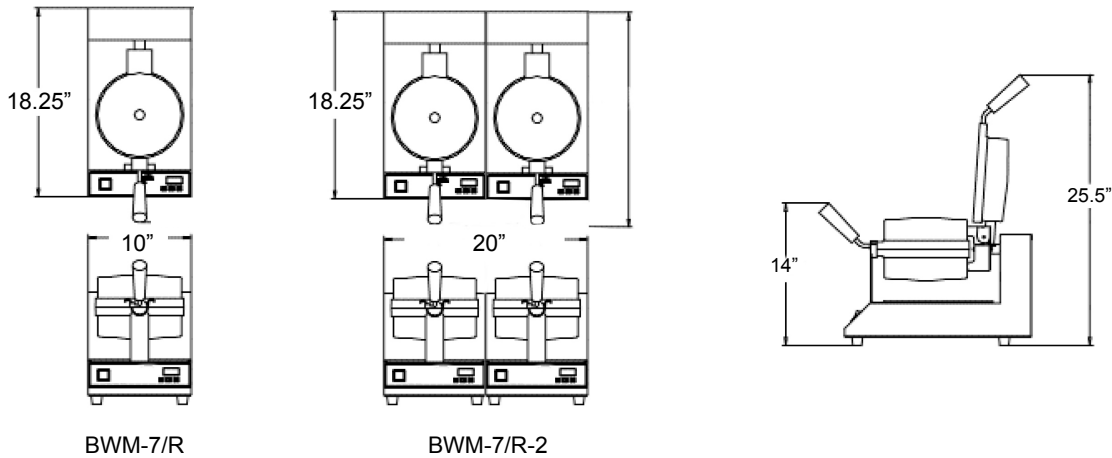

Belgian Waffle Makers - BWM-7/R, BWM-7/R-2

Plan View



Specifications

Item Number	Description	Volts	Wattage	Amps	NEMA Plug
BWM-7/R	7" Round Single Belgian Waffle Maker	120V	1080W	9	5-15P 
BWM-7/R-2	7" Round Double Belgian Waffle Maker	120V	2000W	16.6	5-15P  

Item Number	Item Dimensions	Waffles Per Hour	Temperature Range	Timer
BWM-7/R	10"W x 18.25"D x 14"H	20 - 7" x 1.25"	250° - 425°F	0-15 minutes
BWM-7/R-2	20"W x 18.25"D x 14"H	40 - 7" x 1.25"	250° - 425°F	0-15 minutes

*Height with waffle irons open is 25.5"H

Shipping Info

Item Number	Box Dimensions	Gross Weight	Net Weight
BWM-7/R	12"W x 20"D x 14"H	26 lbs	24 lbs
BWM-7/R-2	20.25"W x 20"D x 14"H	49 lbs	42 lbs

For more information about this or any of our other products go to www.admiralcraft.com. These items are listed on AutoQuotes. For full explanation of warranty coverage on this product please refer to warranty page located in the owner's manual and warranty section at www.admiralcraft.com. Specifications subject to change without notice. Please confirm at time of order.

Specifications

Description

Cook up light and fluffy 4" x 6" rectangular shaped waffles with Adcraft's new Brussels style waffle maker. Constructed with a stainless steel body for durability and easy cleaning. The heavy duty cast iron plates open up to 90° and heat up evenly and quickly giving you that perfect golden brown waffle in just under 2 minutes. The easy to use, manual thermostat knob gives you precise control over the cooking temperature. The heating indicator lets you know when the plates get to temperature and are ready to cook. Comes complete with removable stainless steel drip tray and two pronged waffle fork for easy removal. 120V, 1780W and 15 Amps. 4' long power cord with a NEMA 5-15 plug. This unit is backed by Adcraft's 1 year warranty.

Construction

- Commercial quality heavy duty stainless steel construction
- Heavy duty cast iron waffle plates and hinges
- Cool-to-touch bakelite handle for easy opening and closing
- Rubber feet for stability

Operation

- Manual adjustable thermostat ranges from 120° to 520°F
- Cast iron plates open 90° and cook on both the top and bottom
- Heating indicator lets you know when plates are hot and ready for the next batch of waffles

Electrical

- 120V, 1780W, 15 Amps
- 4' power cord with NEMA 5-15 plug

Certifications/Approvals

Waffle Maker - 4" x 6" Double *Brussels style - Rectangular*

Models:

- WM-6D/S



Warranty: This product is protected by Admiral Craft Equipment Corporation's 1 year limited warranty. Should your product fail under normal use it will be repaired or replaced up to one year from date of purchase.



4" x 6" Brussels Style Waffle Maker - WM-6D/S

Plan View

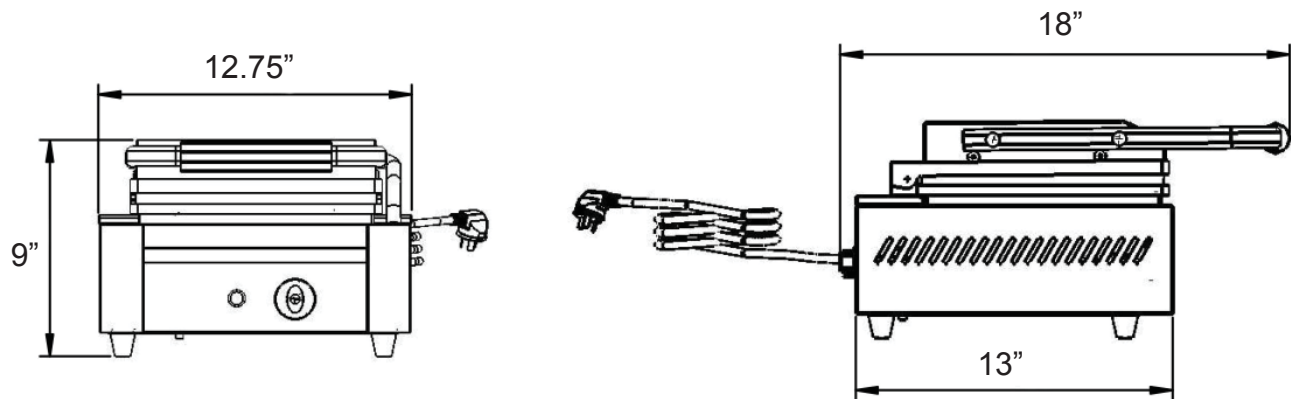

Specifications

Item Number	Description	Volts	Wattage	Amps	NEMA Plug
WM-6D/S	Brussels Style Waffle Maker	120V	1780W	15	5-15P 

Item Number	Item Dimensions	Shape and Size of Waffles	Temperature Range	Plates
WM-6D/S	12.75"W x 18"D x 9"H*	Double Rectangular 4" x 6" waffles	120° - 520°F	Cast Iron

*Height with waffle iron open is 21"

Shipping Info

Item Number	Box Dimensions	Gross Weight	Net Weight
WM-6D/S	15.5"W x 21"D x 11"H	40 lbs	37.5 lbs

For more information about this or any of our other products go to www.admiralcraft.com. These items are listed on AutoQuotes. For full explanation of warranty coverage on this product please refer to warranty page located in the owner's manual and warranty section at www.admiralcraft.com. Specifications subject to change without notice. Please confirm at time of order.

Specifications

Description

Adcraft's Portable Oil Filtration System is designed to preserve the life of your oil and ensure consistent fried food quality while saving you money. This model filter can hold up to 40 lbs of oil at one time. This compact, low profile unit is constructed of all stainless steel and mounted on 4 swivel casters for easy movement and storage. The low profile body allows for easy placement under the fryer drain. The included stainless steel cover keeps the unit safe and clean while not in use. This unit is backed by Adcraft's one year replace or repair warranty.

Construction

- Constructed of heavy duty stainless steel
- Removable flexible filtering hose is 5' long and equipped with a stainless steel nozzle and cool-to-touch handle
- Mounted on 4 (2 locking) swivel casters for easy movement
- Fold down handle allows for safe and easy transporting
- Stainless steel cover keeps unit safe and clean while not in use

Controls

- Separate on/off power switch
- Pump button allows for start/stop of filtering cycle

Filter Chamber

- Large 18"x13" chamber that holds up to 40 lbs of oil
- Includes stainless steel gasket, filter mesh and rubber gasket
- Pumps up to 5 gallons of oil per minute

Electrical

- 1/3 HP motor, 120V, 200W
- 5' removable power cord with NEMA 5-15 plug

Includes

- Filter papers
- Filter powder
- Stainless steel cover

Certifications/Approvals

Portable Oil Filtration System

Models:

- OF-40



Separate "power" and "pump" controls



Oil Filter shown with stainless steel cover (included)

Warranty: This product is protected by Admiral Craft Equipment Corporation's 1 year limited warranty. Should your product fail under normal use it will be repaired or replaced up to 1 year from date of purchase.



Date: _____
 Item No.: _____
 Project No.: _____

Portable Oil Filtration System - OF-40

Plan View

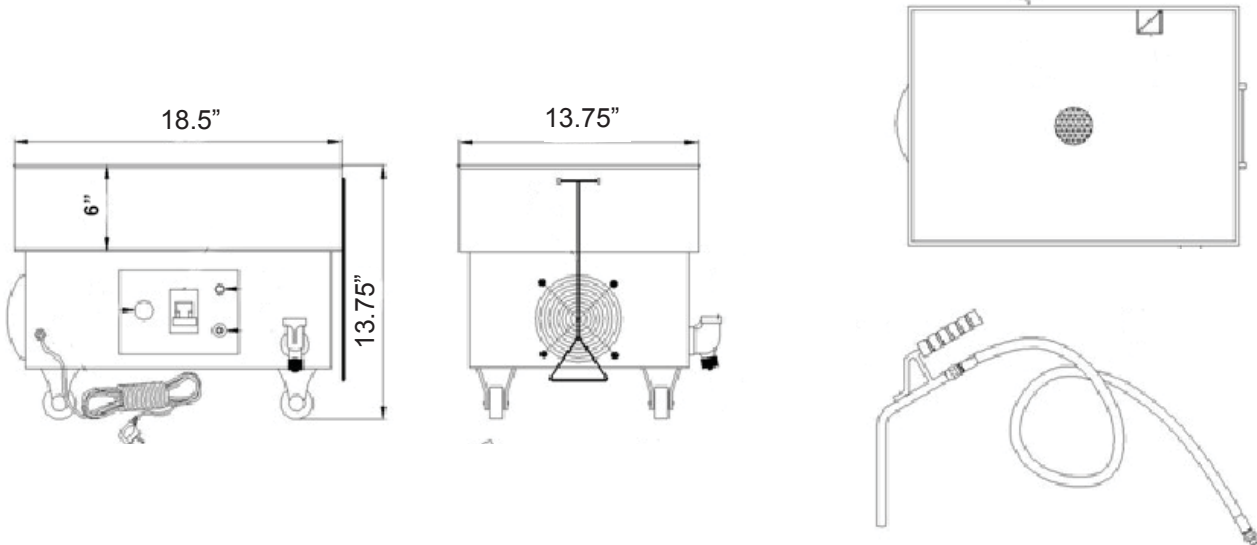

Filtering hose is 5' long with a 1' nozzle

Specifications

Item Number	Description	Horsepower	Oil Capacity	Volts	Wattage	NEMA Plug
OF-40	40 lb Portable Oil Filter	1/3 HP	40 lbs	120V	200W	5-15P 

NOTE: This unit pumps 5 gallons of oil per minute.

Shipping Info

Item Number	Box Dimensions	Item Dimensions	Gross Weight	Net Weight
OF-40	24.5"x19.25"x 19.25"	18.5" x 13.75" x 13.75"	108 lbs	92.5 lbs

For more information about this or any of our other products go to www.admiralcraft.com. This item is listed on AutoQuotes. For full explanation of warranty coverage on this product please refer to warranty page located in the owner's manual and warranty section at www.admiralcraft.com. Specifications subject to change without notice. Please confirm at time of order.

Specifications

Description

Adcraft's gear driven commercial planetary mixers are perfect for any small bakery, restaurant, deli and more. Their heavy duty construction and powerful motor will easily handle any type of mixing task needed with ease. Three fixed speeds and its direct drive 100% gear driven transmission allow the mixers to maintain a consistent mixing speed no matter how much product is in the mixing bowl. Comes complete with a stainless steel mixing bowl, wire whisk, dough hook and flat beater attachments. The PM-20 and PM-30 mixers also have a #12 hub for meat grinding attachments. 120V. 5' long power cord with a NEMA 5-15 plug. This unit is ETL Listed and ETL Sanitation and backed by Adcraft's 1 year replace or repair warranty.

Construction

- Heavy duty construction
- Stainless steel wire safety guard around bowl
- Stainless steel bowl clamps hold mixing bowl securely in place during operation
- Rubber inserts on feet for stability

Operation

- Powerful motors
- Direct drive 100% gear driven transmission for consistent mixing speed
- Three fixed mixing speeds with easy shift
- Push button On/Off switch
- 60 minute timer on the PM-20 and PM-30 models

Electrical

- 120V
- 5' power cord with NEMA 5-15 plug
- Single phase electrical rating

Attachments

- Includes wire whisk, dough hook and flat beater
- Stainless steel mixing bowl
- PM-20 and PM-30 feature a #12 hub for meat grinding attachments

Certifications/Approvals



Planetary Mixers

Models:

- PM-10 - 10 Quart Mixer
- PM-20 - 20 Quart Mixer
- PM-30 - 30 Quart Mixer



PM-20 model shown

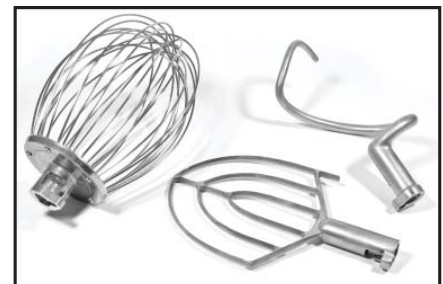

Warranty: This product is protected by Admiral Craft Equipment Corporation's 1 year limited warranty. Should your product fail under normal use it will be repaired or replaced up to one year from date of purchase.



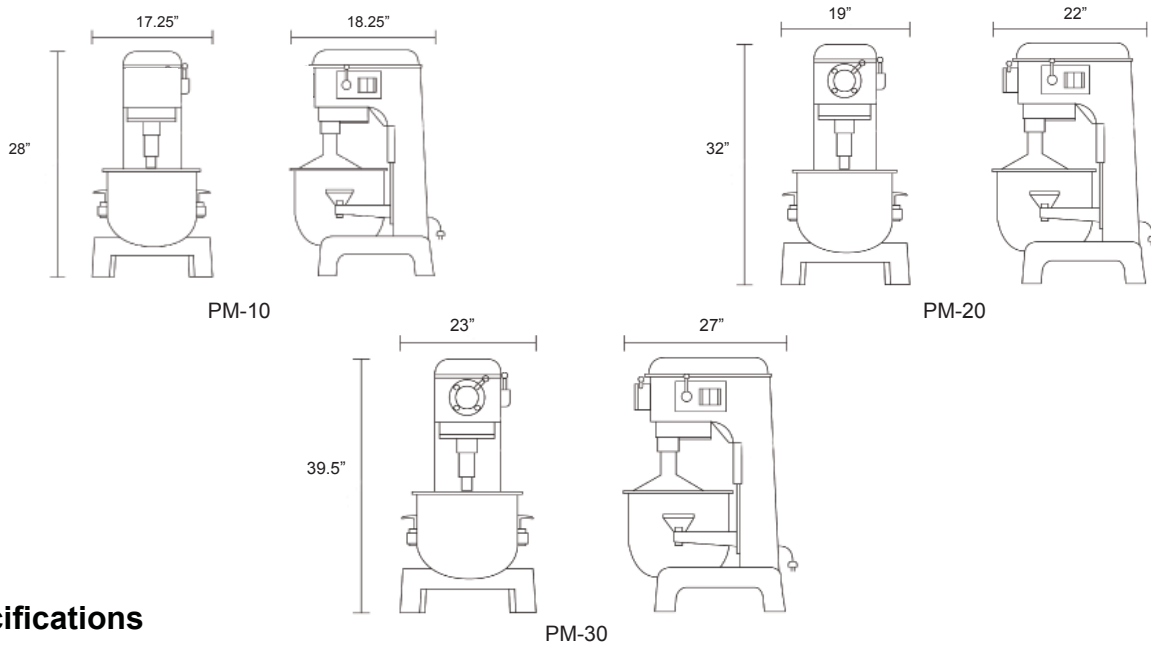

Planetary Mixers - PM-10, PM-20, PM-30

Plan View



Specifications

Item Number	Description	Volts	Wattage	Amps	Horsepower	NEMA Plug
PM-10	Planetary Mixer 10 Qt.	120V	600W	5	0.75 HP	5-15P 
PM-20	Planetary Mixer 20 Qt.	120V	1100W	9	1.5 HP	5-15P 
PM-30	Planetary Mixer 30 Qt.	120V	1800W	15	2.4 HP	5-15P 

Item Number	Item Dimensions	Speeds	RPM's	Hub Attachment	Timer
PM-10	17.25"W x 18.25"D x 28"H	Three	113/184/341	N/A	N/A
PM-20	19"W x 22"D x 32"H	Three	108/199/382	#12	0-60 minutes
PM-30	23"W x 27"D x 39.5"H	Three	84/151/270	#12	0-60 minutes

Shipping Info

Item Number	Box Dimensions	Gross Weight	Net Weight
PM-10	21.25"W x 19"D x 28"H	157 lbs	125 lbs
PM-20	24.75"W x 22.25"D x 34.25"H	250 lbs	205 lbs
PM-30	28"W x 25.25"D x 44.5"H	394 lbs	345 lbs

For more information about this or any of our other products go to www.admiralcraft.com. This item is listed on AutoQuotes. For full explanation of warranty coverage on this product please refer to warranty page located in the owner's manual and warranty section at www.admiralcraft.com. Specifications subject to change without notice. Please confirm at time of order.

Specifications

Description

Adcraft's stainless steel electric salamanders are great for cooking, grilling, re-heating and holding foods. The adjustable upper housing has powerful, independently controlled heating element(s) that will both cook and re-heat food quickly when needed. Infinite control dial(s) allow you to have precise control over how long the heating period lasts. The removable drip tray and cooking grate allow for easy cleaning. These salamanders can be used on the countertop or mounted to the wall with their special wall mounting bracket system (sold separately). These units are 240V and come with a 4' long power cord that has a NEMA 6-20P plug. This unit is backed by Adcraft's 1 year warranty.

Construction

- Commercial quality heavy duty stainless steel construction
- Stainless steel upper housing has a vertical movement of 8" to 2.75"
- Polished reflectors above the heating element(s) to help radiate heat down towards the cooking area
- Removable stainless steel drip tray and cooking grate
- Cool-to-touch bakelite handle for safe adjusting of the upper housing
- Non-slip rubber feet for stability when using on the countertop

Operation

- Adjustable vertical movement upper housing adjusts the intensity of the heat given off by the heating element(s)
- Infinite control dial allows you to precisely control how long the heating period lasts

Electrical

- 240V, Single phase
- 4' power cord with NEMA 6-20plug
- Can be used with a plug or hardwired
- Plug and hardwire are both located on the bottom lower right of the unit

Mounting

- Optional wall mounting bracket sold separately
- SAL-2800W/MB and SAL-4000W/MB

Certifications/Approvals

Electric Salamanders

Models:

- SAL-2800W
- SAL-4000W



SAL-2800W



SAL-4000W

Warranty: This product is protected by Admiral Craft Equipment Corporation's 1 year limited warranty. Should your product fail under normal use it will be repaired or replaced up to one year from date of purchase.



Electric Salamanders - SAL-2800W, SAL-4000W

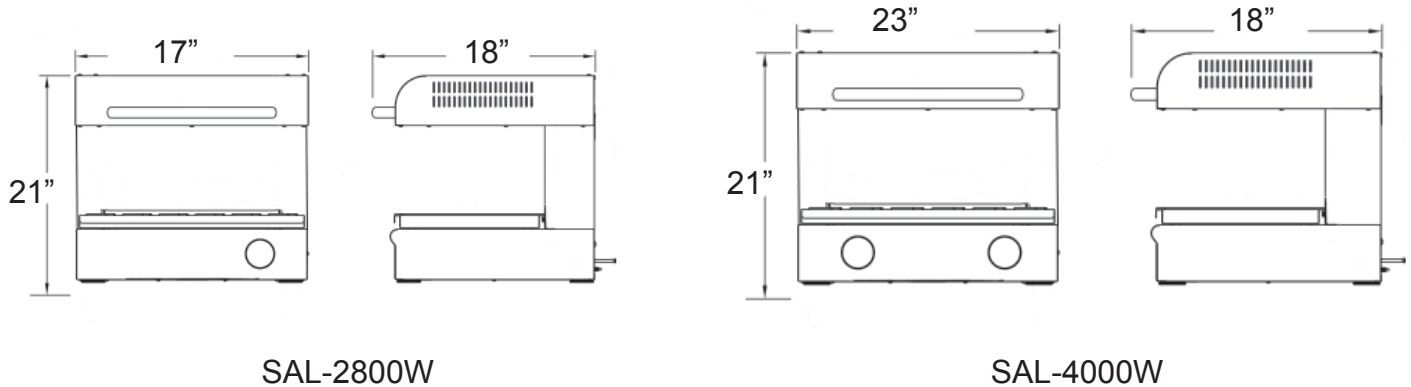

Plan View



SAL-2800W

SAL-4000W

Specifications

Item Number	Description	Volts	Wattage	Amps	NEMA Plug
SAL-2800W	17" Electric Salamander	240V	2800W	11.6	6-20P 
SAL-4000W	23" Electric Salamander	240V	4000W	16.6	6-20P 

Item Number	Overall Dimensions	Cooking Area	Vertical Movement of Upper Housing*
SAL-2800W	17.75"W x 18"D x 21"H	17"W x 13"D	8" to 2-3/4"
SAL-4000W	23.75"W x 18"D x 21"H	23"W x 13"D	8" to 2-3/4"

*Top position to bottom position

Shipping Info

Item Number	Box Dimensions	Gross Weight	Net Weight
SAL-2800W	23" x 23" x 23"	91 lbs	85 lbs
SAL-4000W	23" x 23" x 29"	113 lbs	108 lbs

For more information about this or any of our other products go to www.admiralcraft.com. These items are listed on AutoQuotes. For full explanation of warranty coverage on this product please refer to warranty page located in the owner's manual and warranty section at www.admiralcraft.com. Specifications subject to change without notice. Please confirm at time of order.

©2015 Admiral Craft Equipment Corp.

Specifications

Description

Adcraft's stainless steel cheesemelters are perfect for quickly melting cheese, toasting nachos or sandwiches and finishing. Their small footprint and compact design make them perfect for kitchens with limited space. These units use a metal sheath heating element that will quickly warm, toast and melt to perfection. The body is insulated to prevent heat from escaping the melting chamber. The infinite switch gives you precise control over the amount of heat given off. It's multi-position food rack allows you to set the food at the perfect distance away from the heat source. A 15 minute timer is standard on the CHM-1200W model. These units are and backed by Adcraft's 1 year warranty.

Construction

- Heavy duty stainless steel construction
- Metal sheath heating element heats up quickly and distributes the heat evenly down towards the food
- Insulated body to prevent heat loss inside the melting chamber
- Built in 4 slot multi-position racking system allows for the perfect distance away from the heat source for all types of food
- Removable food grid with 6" cool-to-touch bakelite handles
- Removable stainless steel crumb tray for easy cleaning
- Non-slip rubber feet for stability

Operation

- Infinite control dial allows you to precisely control how long the heating period lasts
- 15 minute timer comes standard on the CHM-1200W model
- Indicator light lets you know when element is heating

Electrical

- CHM-1200W is 120V and has a NEMA 5-15 plug
- CHM-2400W and CHM-4350W are 240V and have a NEMA 6-20 plug
- 4' long power cord standard on all models

Certifications/Approvals

Electric Cheesemelters

Models:

- CHM-1200W
- CHM-2400W
- CHM-4350W



CHM-1200W



CHM-2400W



CHM-4350W

Warranty: This product is protected by Admiral Craft Equipment Corporation's 1 year limited warranty. Should your product fail under normal use it will be repaired or replaced up to one year from date of purchase.



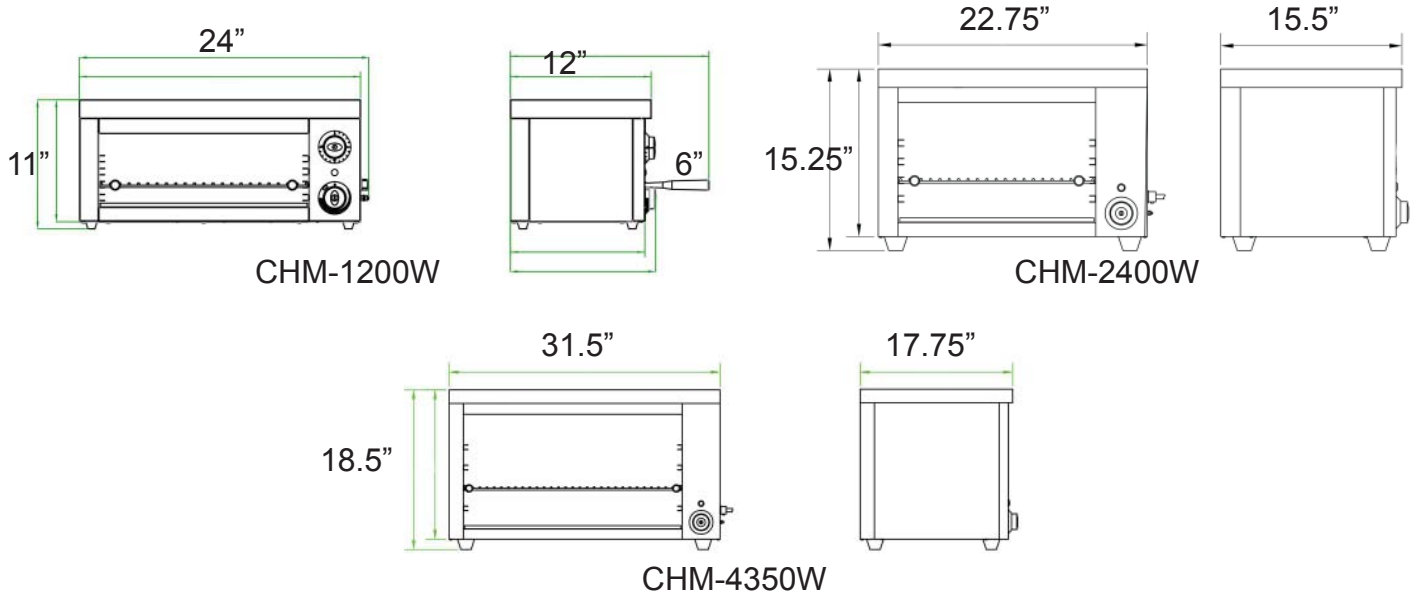

Electric Cheesemelters - CHM-1200W, CHM-2400W, CHM-4350W

Plan View



Specifications

Item Number	Description	Volts	Wattage	Amps	NEMA Plug
CHM-1200W	24" Electric Cheesemelter	120V	1200W	10	5-15P 
CHM-2400W	23" Electric Cheesemelter	240V	2400W	10	6-20P 
CHM-4350W	32" Electric Cheesemelter	240V	4350W	18	6-20P 

Item Number	Overall Dimensions	Melting Chamber Dimensions	Food Rack Dimensions*
CHM-1200W	24"W x 12"D x 11"H	18"W x 10.5"D x 6"H	17.5" x 10"
CHM-2400W	22.75"W x 15.5"D x 15.25"H	16.75"W x 13.5"D x 10.25"H	16.75" x 13.25"
CHM-4350W	31.5"W x 17.75"D x 18.5"H	25.25"W x 16"D x 13.5"H	25.25" x 15.75"

*Does not include handles

Shipping Info

Item Number	Box Dimensions	Gross Weight	Net Weight
CHM-1200W	27" x 15" x 13"	42 lbs	37.5 lbs
CHM-2400W	24.75" x 17.25" x 16"	44 lbs	40 lbs
CHM-4350W	34.25" x 19.5" x 19.5"	67 lbs	61 lbs

For more information about this or any of our other products go to www.admiralcraft.com. These items are listed on AutoQuotes. For full explanation of warranty coverage on this product please refer to warranty page located in the owner's manual and warranty section at www.admiralcraft.com. Specifications subject to change without notice. Please confirm at time of order.

©2015 Admiral Craft Equipment Corp.

Specifications

Description

Adcraft's chamber vacuum packaging machine is ideal for all of your preserving, marinading, pickling and seasoning needs. This powerful tabletop chamber vacuum packaging machine works well with liquids and liquid-rich foods. It sucks the air out of the entire chamber when sealing, not just the bag itself. This means the air pressure is equalized both inside and outside of the bag, keeping liquids in and ensuring a superior seal every time. Constructed with a stainless steel body, this unit has a digital front control display that makes it easy to use. The smoky-clear lid lets you see and monitor the vacuum process. A powerful 1/2 hp oil pump provides up to 29.5" Hg of suction. The 11" wide sealing bar provides maximum results and long lasting usage. It also comes with filler plates to use when sealing smaller batches. 110V, 370W, 3 amps and a detachable 9' long power cord with a NEMA 5-15 plug. This unit is CE Certified and backed by Adcraft's 1 year replace or repair warranty.

Construction

- Body is constructed of polished stainless steel
- Interior chamber has a stainless steel liner
- Smoky-clear lid with lock that opens up 45°
- Easy to use front control panel with digital display
- Separate on/off power switch on the side of the unit
- Rubber feet for stability

Sealing Chamber

- Can apply up to 29.5" Hg of suction per seal
- 11" wide sealing bar
- Interior chamber measures 15.25"D x 11.5"W x 2.75"H
- Comes with two filler plates to use with smaller batches

Electrical

- 1/4 HP oil pump
- 110V, 370W, 3 Amps
- Detachable 9' power cord with NEMA 5-15 plug

Vacuum Packaging Machine

Models:

- VS-300



Comes Standard With:

- 3 oz bottle of oil for pump
- 2 filler plates

Accessories Sold Separately:

- Assorted size sealing bags
- Multi-ring bag stand

Certifications/Approvals



Warranty: This product is protected by Admiral Craft Equipment Corporation's 1 year limited warranty. Should your product fail under normal use it will be repaired or replaced up to one year from date of purchase.



Vacuum Packaging Machine - VS-300

Plan View

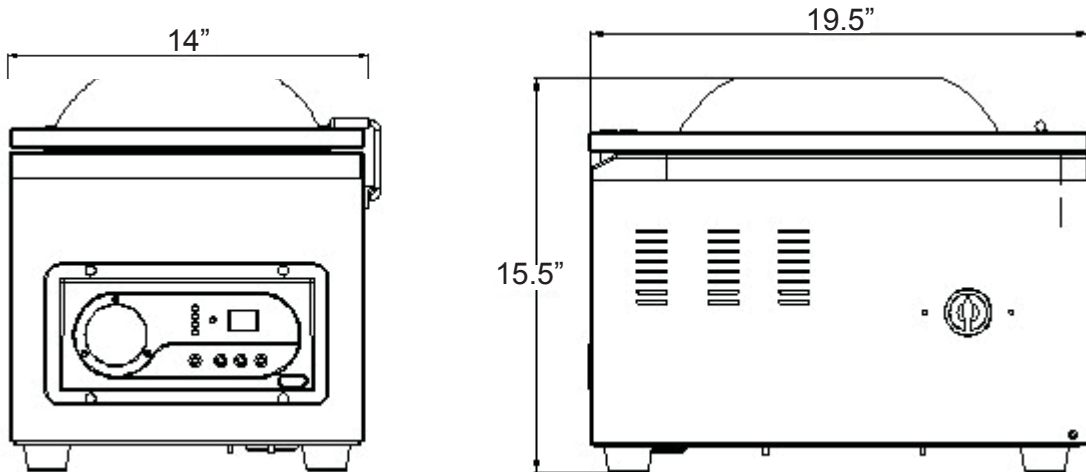

Specifications

Item Number	Description	Suction	HP	Wattage	Volts/Amps	NEMA Plug
VS-300	Vacuum Packaging Machine	29.5" Hg	1/4	370W	110V/3 Amps	5-15P 

Chamber Dimensions (wx dx h) in inches	Overall Dimensions (wx dx h) in inches	Sealing Bar	Cycle Time
11.5"W x 15.25"D x 2.75"H	14"W x 19.5"D x 15.5"H	11" wide	25-40 seconds

Shipping Info

Box Dimensions	Gross Weight	Net Weight
16.5"W x 23.5"D x 19"H	99 lbs	85 lbs

For more information about this or any of our other products go to www.admiralcraft.com. This item is listed on AutoQuotes. For full explanation of warranty coverage on this product please refer to warranty page located in the owner's manual and warranty section at www.admiralcraft.com. Specifications subject to change without notice. Please confirm at time of order.

©2016 Admiral Craft Equipment Corp.

Specifications

Description

Sous Vide is a cooking method in which the food is vacuum sealed in a plastic pouch and then cooked in a water bath at a pre-set temperature. This provides more control with consistent results every time. Adcraft's Sous Vide immersion circulator will help you achieve that perfect texture, taste and tenderness for all meats, seafood and vegetables. Cook food to the desired temperature safely and never overcook your food again. Our Sous Vide immersion circulator features a digital LED temperature display that accurately gauges water temperature to within 0.1 degree. Cooking different types of food is easy with its different pump speed settings. This unit allows you to program up to three cooking settings at a time. This unit is CE Certified and backed by Adcraft's 1 year replace or repair warranty.

Construction

- Stainless steel housing
- Easy to read digital LED temperature display

Operation

- Temperature stability to 0.1°F (0.06°C) for precise, consistent results every time
- Three programmable settings for ease of use
- Two pump speeds for controlled cooking
- Accurate LED temperature (Fahrenheit and Celsius) display for precise cooking

Electrical

- 120V, 1200W, 10 Amps
- 6' power cord with NEMA 5-15 plug

Sous Vide Immersion Circulator

Models:

- SV-1200W



Certifications/Approvals



Warranty: This product is protected by Admiral Craft Equipment Corporation's 1 year limited warranty. Should your product fail under normal use it will be repaired or replaced up to one year from date of purchase.



Date: _____
 Item No.: _____
 Project No.: _____

Sous Vide Immersion Circulator - SV-1200W

Plan View

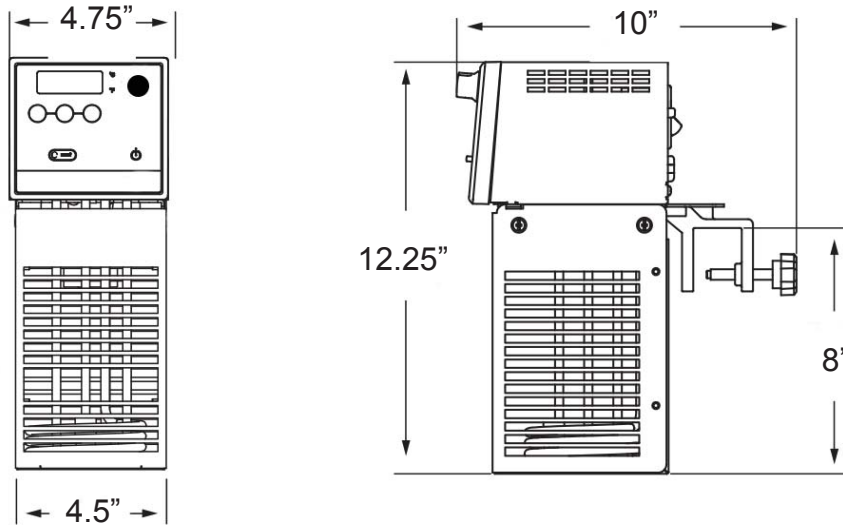

Specifications

Item Number	Description	Volts	Wattage	Amps	NEMA Plug
SV-1200W	Sous Vide Immersion Circulator	120V	1200W	10	5-15P 

Shipping Info

Item Number	Item Dimensions	Shipping Dimensions	Gross Weight	Net Weight
SV-1200W	4.75"W x 10"D x 12.25"H	12"W x 8"D x 15.5"H	10 lbs	8 lbs

For more information about this or any of our other products go to www.admiralcraft.com. This item is listed on AutoQuotes. For full explanation of warranty coverage on this product please refer to warranty page located in the owner's manual and warranty section at www.admiralcraft.com. Specifications subject to change without notice. Please confirm at time of order.

©2017 Admiral Craft Equipment Corp.

Admiral Craft Equipment Corp.

800 Shames Drive • Westbury, NY 11590 • P: 800-223-7750 • F: 800-447-7751 • www.admiralcraft.com

Specifications

Description

Adcraft's new open well steam tables are constructed of stainless steel with galvanized steel wells and adjustable legs. Available in three popular sizes; 2, 3 and 4 bay, these units are built to handle the toughest of kitchen environments. Each steam table features individually controlled 750W heating elements with their own dedicated control switch. The 8" deep wells are designed to fit full size spillage pans (not included). An adjustable stainless steel undershelf allows for storage. Each size comes with a 8" x 1/2" polycarbonate cutting board that runs the whole width of the unit and is removable for easy cleaning. All units come with Adcraft's 1 year limited warranty.

Construction

- Heavy duty stainless steel body
- Die-stamped beading openings that measure 12" x 20"
- 8" x 1/2" polycarbonate cutting board that runs the whole width of the unit and is removable for easy cleaning
- Galvanized legs with adjustable bullet ends
- Adjustable stainless steel undershelf for storage

Controls

- Individually controlled infinite switches for each compartment
- Red indicator light that stays on while being used to let user know which compartments are heating

Heat Compartments

- 8" deep open wells that are lined with galvanized steel
- Each heat compartment is fully insulated on all four sides and bottom with 1" thick insulation

Electrical

- Each compartment has its own individually controlled 750W element
- 6' power cord with plug extends out from underneath the unit
- 2 and 3 bay models are 120V
- 4 bay model is 208V/240V

Open Well Steam Tables Electric - Hot Food, Stationary

Models:

- ST-120/2 - 2 Bay
- ST-120/3 - 3 Bay
- ST-240/4 - 4 Bay



ST-120/2
model shown

Accessories

- SPIL-21 - 21 qt. spillage pan

Certifications/Approvals



Warranty: This product is protected by Admiral Craft Equipment Corporation's one year limited warranty. Should your product fail under normal use it will be repaired or replaced up to one year from date of purchase.



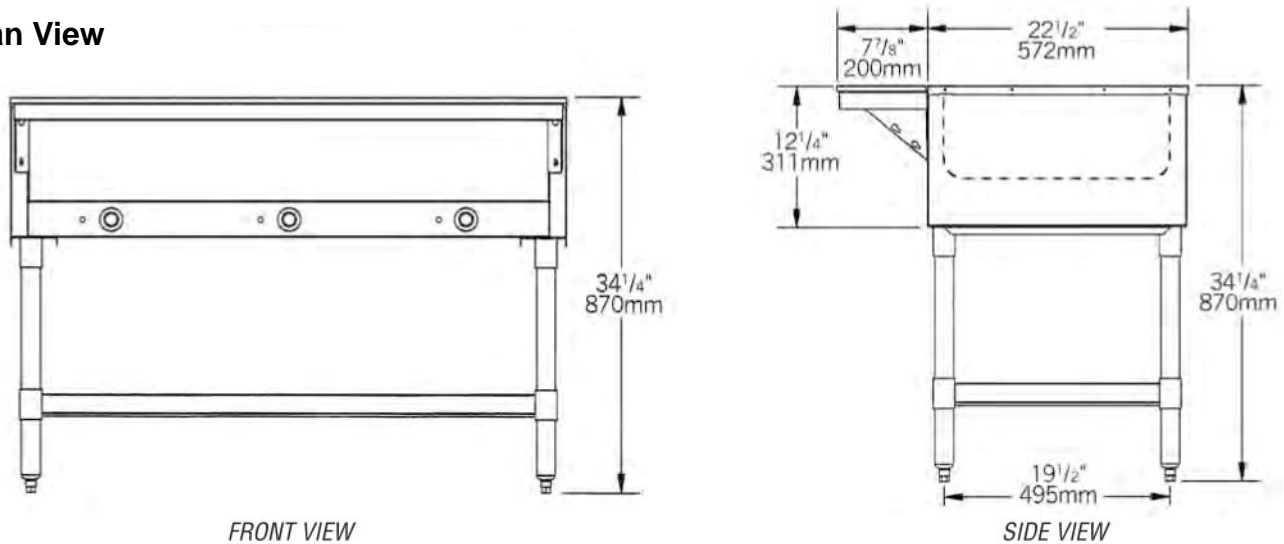

Open Well Steam Tables - Electric - Hot Food, Stationary

Plan View



Specifications

Item Number	Well Openings	Volts	Wattage	Amps	NEMA Plug
ST-120/2	2	120V	1500W	12.5	5-15P 
ST-120/3	3	120V	2250W	18.75	5-20P 
ST-240/4	4	208V/240V	3000W	12.5	6-20P 

Shipping Info

Item Number	Dimensions	Gross Weight	Net Weight
ST-120/2	33"W x 31"D x 34.25"H	89.5 lbs	82.5 lbs
ST-120/3	48.5"W x 31"D x 34.25"H	112.5 lbs	104.75 lbs
ST-240/4	63.75" x 31"D x 34.25"H	141 lbs	130 lbs

For more information about this or any of our other products go to www.admiralcraft.com. This item is listed on AutoQuotes. For full explanation of warranty coverage on this product please refer to warranty page located in the owner's manual and warranty section at www.admiralcraft.com. Specifications subject to change without notice. Please confirm at time of order.

Specifications

Description

Adcraft's electric water bath steam table is constructed of all stainless steel. All four top openings fit a 12" x 20" full size food pan with no additional water pans needed. The stainless steel water pan is fully welded and has a recessed well that houses the immersed heating element. Thermostatic temperature dial allows for accurate food holding temperature. Comes standard with adjustable stainless steel legs, undershelf and a 3/4" drainage pipe for easy removal of water. The steam table is customized with the optional stainless steel tray rack and optional 9" wide polycarbonate cutting board shelf. This unit ships knocked down and assembly is required. This unit is backed by Adcraft's 1 year limited warranty.

Construction

- Heavy duty stainless steel body and well
- 4 top openings that fit 12" x 20" full size food pans
- Stainless steel legs with adjustable bullet ends
- Stainless steel undershelf for storage

Water Pan

- Fully welded 304 stainless steel construction
- Recessed well with 3000W immersed heating element
- 3/4" drain for quick and easy draining

Electrical

- Single 3000W heating element that runs throughout the bottom of the water well
- Thermostatic control dial
- 5' power cord with NEMA 6-20 plug extends out from underneath the unit
- Low water cutoff sensor with reset button
- 208V/240V, 3000W, 12.5 Amps

Available Options & Accessories

- EST-240/TH - Stainless steel tray holder
- EST-240/PCB - 9" wide cutting board and s/s shelf

Certifications/Approvals



Water Bath Steam Table Electric - Open Base

Model:

EST-240 - 4 Bay



EST-240 shown with optional cutting board and tray holder



EST-240/TH
Tray Holder



304 Stainless steel
Water Pan Well



EST-240/PCB
9" Cutting Board

Warranty: This product is protected by Admiral Craft Equipment Corporation's one year limited warranty. Should your product fail under normal use it will be repaired or replaced up to one year from date of purchase.



Water Bath Steam Table - Electric - Open Base

Plan View

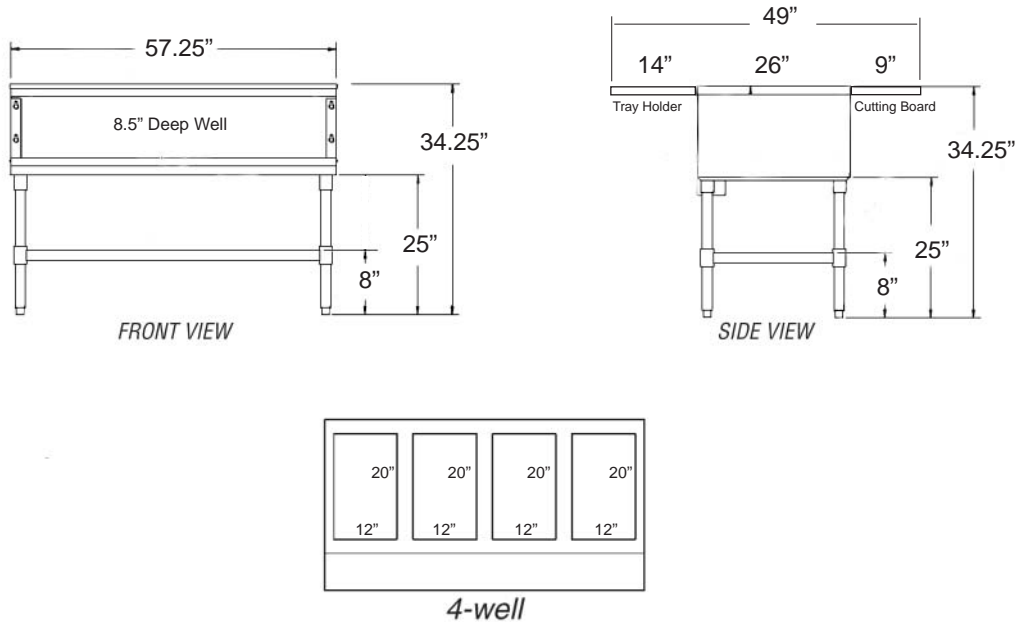

Specifications

Item Number	Well Openings	Volts	Wattage	Amps	NEMA Plug
EST-240	4	208V/240V	3000W	12.5	6-20P 

Shipping Info

Item Number	Description	Dimensions	Gross Weight	Net Weight
EST-240	Water Bath Steam Table - 4 Bay	57.25"W x 26"D* x 34.25"H	79 lbs	68 lbs
EST-240/TH	Stainless Steel Tray Holder	57.25"W x 14"D x 2"H	10 lbs	10 lbs
EST-240/PCB	Polycarbonate Cutting Board w/shelf	57.25"W x 9"D x 1"H	20 lbs	18.75 lbs

*This dimension does not include attached tray rack and cutting board shelf.

For more information about this or any of our other products go to www.admiralcraft.com. This item is listed on AutoQuotes. For full explanation of warranty coverage on this product please refer to warranty page located in the owner's manual and warranty section at www.admiralcraft.com. Specifications subject to change without notice. Please confirm at time of order.

Specifications

Description

Adcraft's non-insulated heater proofer cabinet is ideal for all your food holding and proofing needs. Constructed of non-corrosive aluminum throughout the cabinet that allows you to hold prepared foods at proper serving temperatures for extended periods of time. The air baffle and circulating air blower provide even heat distribution throughout the cabinet. A removable control drawer with LED thermostat gives you complete control over the operating temperature and humidity range and doesn't require opening the door to use. This item comes standard with 5" heavy duty castors and a clear lexon door with aluminum frame. It ships knocked down and is easy to assemble (Tools and hardware kit included). The overall dimensions of this unit are 21"W x 31.25"D x 67.25"H. The cabinet dimensions are 18"W x 26.25"D x 52.75"H which will allow you to fit 36-18" x 26" pans (sold separately). The heating temperature range for this item is 80°F - 185°F and a humidity proofing range of 30% - 100%. It is CE certified and is backed by Adcraft's 1 year replace or repair warranty.

Construction

- Cabinet made of non-corrosive aluminum
- Clear lexon door with aluminum frame
- Ships knocked down and easy to assemble
- 5" heavy duty swivel castors with brakes
- Fits 36 - 18" x 26" pans (not included)

Control Drawer

- Removable control drawer
- Air baffle and circulating air blower provides even heat throughout the cabinet
- Easy to use controls that don't require opening the door
- Flip switch makes it easy to switch from heat to proof modes. Temperature and humidity control dials allow for accurate settings.
- Easy to read LED thermostat
- 120V, 1800W, 15 Amps, NEMA 5-15 plug 

Door

- Clear lexon door with anodized aluminum frame that will not dull
- Door lifts off for easy cleaning and accessibility

Heater Proofer Cabinet Non-Insulated

Models:

- PW-120 - Complete Set
- PW-120/C - Cabinet
- PW-120/H - Control Drawer



(Pans sold separately)

Accessories (Sold Separately)

- BP-1826 - Full size 18"x26" aluminum bun pan

Certifications/Approvals



Warranty: This product is protected by Admiral Craft Equipment Corporation's one year limited warranty. Should your product fail under normal use it will be repaired or replaced up to one year from date of purchase.



Heater Proofer Cabinet - PW-120

Plan View

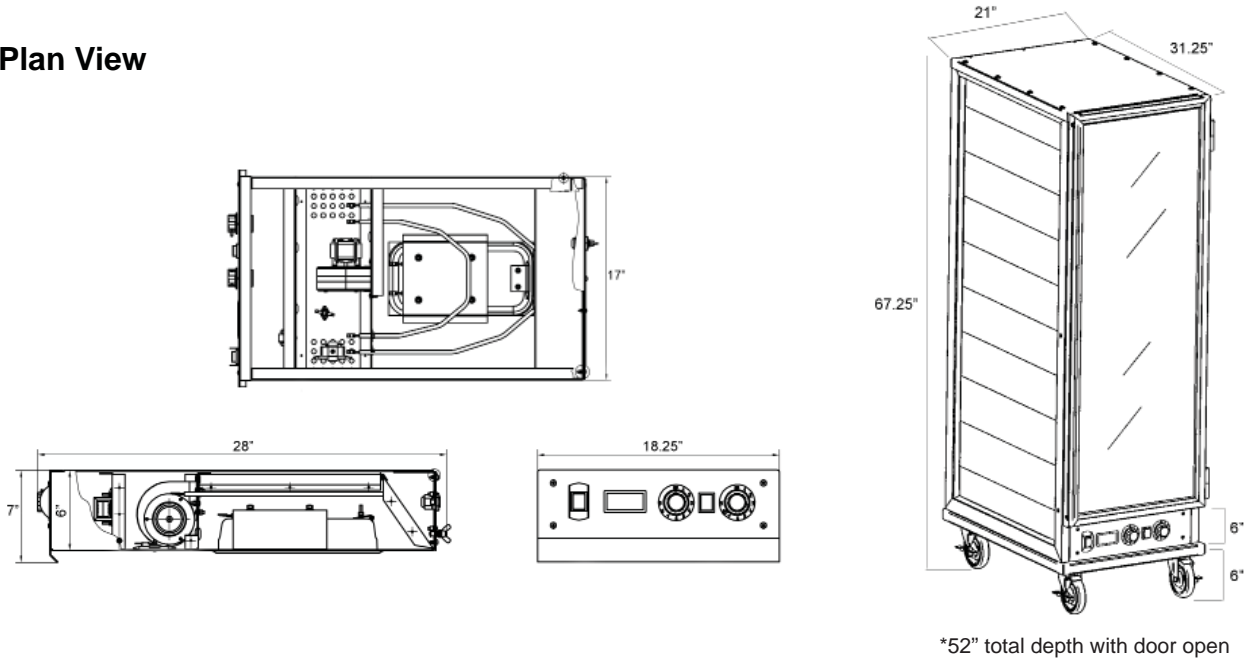

Specifications

Model Number	Description	Wattage	Voltage	Amps
PW-120	Heater Proofer Complete Unit	1800W	120V/60Hz	15
PW-120C	Cabinet w/Door	N/A	N/A	N/A
PW-120H	Control Drawer	1800W	120V/60Hz	15

Item Number	Dimensions	Gross Weight	Net Weight
PW-120	21"W x 31.25"D x 67.25"H	148 lbs (67kgs)	112 lbs (51kgs)
PW-120C	18"W x 26.25"D x 52.75"H	127 (57.5kgs)	94 lbs (42.5kgs)
PW-120H	18.25"W x 28"D x 7"H	21 lbs (9.5kgs)	18 lbs (8.5kgs)

For more information about this or any of our other products go to www.admiralcraft.com. This item is listed on AutoQuotes. For full explanation of warranty coverage on this product please refer to warranty page located in the owner's manual and warranty section at www.admiralcraft.com. Specifications subject to change without notice. Please confirm at time of order.

Specifications

Description

Adcraft's heater proofer control drawer with LED thermostat gives you complete control over the operating temperature and humidity range for inside the cabinet and doesn't require opening the door to use. The heating temperature range this item gives off is 80°F - 185°F and a humidity proofing range of 30% - 100%. The dimensions for this drawer are 18.25"W x 28"D x 7"H and fits most major brands heater proofer cabinets. 120V, 1800W and 15 Amps. It is CE certified and is backed by Adcraft's 1 year replace or repair warranty.

Control Drawer

- Aluminum construction
- Removable control drawer slides securely into place
- Air baffle and circulating air blower provides even heat distribution throughout the cabinet
- Easy to use controls that don't require opening the door
- Temperature and humidity control dials allow for accurate settings.
- Easy to read LED thermostat

Electrical

- 5' power cord with NEMA 5-15 plug 

Heat/Proof controls

- Heating temperature range of 80°F - 185°F
- Humidity proofing range of 30% - 100%
- Flip switch makes it easy to switch from heat to proof mode.

Specifications

Heater Proofer Control Drawer

Model:

PW-120H



Fits the following heater proofers:

- Adcraft PW-120
- Win-Holt NHP and NHPL models

Certifications/Approvals



Model Number	Description	Wattage	Voltage	Amps	Dimensions	Gross Weight	Net Weight
PW-120H	Control Drawer	1800W	120V/60Hz	15	18.25"W x 28"D x 7"H	21 lbs (9.5kgs)	18 lbs (8.5kgs)

Plan View

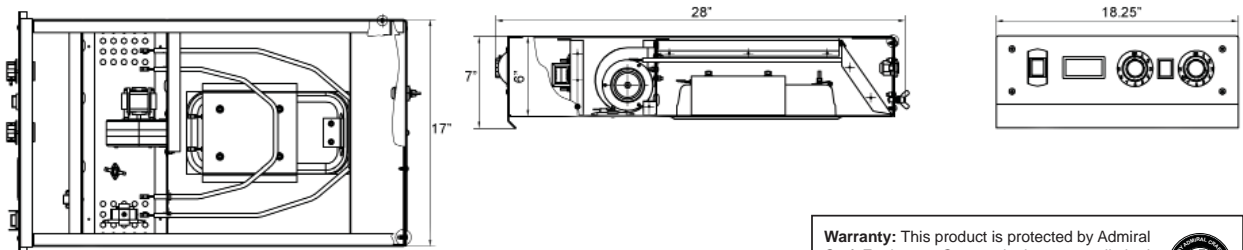

For more information about this or any of our other products go to www.admiralcraft.com. This item is listed on AutoQuotes. For full explanation of warranty coverage on this product please refer to warranty page located in the owner's manual and warranty section at www.admiralcraft.com. Specifications subject to change without notice. Please confirm at time of order.

Warranty: This product is protected by Admiral Craft Equipment Corporation's one year limited warranty. Should your product fail under normal use it will be repaired or replaced up to one year from date of purchase.



Specifications

Description

Adcraft's equipment stands feature a heavy duty 16 gauge stainless steel top and a galvanized steel adjustable undershelf. The top shelf can hold up to 800 lbs and the undershelf has a limit of up to 600 lbs. The 1-5/8" diameter legs come with adjustable ABS bullet feet. These equipment stands are NSF Listed and are a must have for all foodservice establishments.

Construction

- Heavy duty 16 gauge stainless steel top shelf that can hold up to 800 lbs
- 18 gauge adjustable undershelf is made of galvanized steel and can hold up to 600 lbs
- The support beams under the top shelf are constructed of galvanized steel and run throughout the width of the shelf
- All undershelf corners are aluminum
- The 1-5/8" diameter legs are made of galvanized steel and have adjustable ABS bullet feet
- Screws and hardware included

Certifications/Approvals



Stainless Steel Equipment Stands -Galvanized undershelf and legs

Models:

24" Depth

- ES-2424
 ES-2436
 ES-2448

30" Depth

- ES-3024
 ES-3036
 ES-3048
 ES-3060
 ES-3072



Specifications

Item Number	Description (DxWxH in inches)	Support Beams	Legs	Top Shelf Capacity	Undershelf Capacity
ES-2424	Equipment Stand 24" x 24" x 24"	2 pcs	4	800 lbs	600 lbs
ES-2436	Equipment Stand 24" x 36" x 24"	2 pcs	4	800 lbs	600 lbs
ES-2448	Equipment Stand 24" x 48" x 24"	2 pcs	4	800 lbs	600 lbs
ES-3024	Equipment Stand 30" x 24" x 24"	3 pcs	4	800 lbs	600 lbs
ES-3036	Equipment Stand 30" x 36" x 24"	3 pcs	4	800 lbs	600 lbs
ES-3048	Equipment Stand 30" x 48" x 24"	3 pcs	4	800 lbs	600 lbs
ES-3060	Equipment Stand 30" x 60" x 24"	3 pcs	6	800 lbs	600 lbs
ES-3072	Equipment Stand 30" x 72" x 24"	3 pcs	6	800 lbs	600 lbs

For more information about this or any of our other products go to www.admiralcraft.com. These items are listed on AutoQuotes. Specifications subject to change without notice. Please confirm at time of order.

ACE Equipment One Year Limited Warranty

Admiral Craft Equipment Corp. (ACE) warrants its equipment against defects in materials and workmanship, subject to the following conditions:

ACE Equipment is warranted for one year, effective from the date of purchase by the original owner. A copy of the original receipt or other proof of purchase is required to obtain warranty coverage. This warranty applies to the original owner only, and is not assignable.

Should any product fail to function in its intended manner under normal use within the limits defined in this warranty, at ACE's discretion, such product will be repaired, replaced with a refurbished unit, or replaced with a new unit by ACE, after defective unit has been inspected and defect has been confirmed. ACE does not assume any liability for extended delays in replacing any item beyond its control. This warranty does not apply to rubber and non-metallic synthetic parts that may need to be replaced due to normal usage, wear or lack of preventative maintenance.

This warranty covers products shipped into the 48 contiguous United States, Hawaii, and metropolitan areas of Alaska and Canada. Warranty coverage on products used outside the 48 contiguous United States, Hawaii and metropolitan areas of Alaska and Canada may vary. Contact ACE for details at 1-800-223-7750

The following conditions are not covered by warranty:

- Equipment failure relating to improper installation, improper utility connection or supply and problems due to improper ventilation.
- Equipment that has not properly been maintained, damage from improper cleaning, and water damage to controls.
- Equipment that has not been used in an appropriate manner, or has been subject to misuse, neglect, abuse, accident, alteration, negligence, damage during transit, delivery or installation, fire, flood, riot, or act of God.
- Equipment that has the model number or serial number removed or altered.
- Equipment on which the security seal has been broken.

If the equipment has been changed, altered, modified, or repaired without express written permission from ACE, then the manufacturer shall not be liable for any damages to any person or to any property, which may result from the use of this equipment thereafter.

This equipment is intended for commercial use only and this warranty is void if equipment is used in other than a commercial application.

For warranty and non-warranty related issues, technical support, purchase replacement parts and warranty registration visit www.admiralcraft.com. Please have your model number, serial number and proof of purchase ready. It is not necessary to contact the place where you originally purchased your product from.

“THE FOREGOING WARRANTY IS IN LIEU OF ANY AND ALL WARRANTIES EXPRESSED OR IMPLIED INCLUDING ANY IMPLIED WARRANTY OF MERCHANTABILITY OR FITNESS FOR PARTICULAR PURPOSES AND CONSTITUTES THE ENTIRE LIABILITY OF ACE. IN NO EVENT DOES THE LIMITED WARRANTY EXTEND BEYOND THE TERMS STATED HEREIN.”